

Maximum Performance Contoured Diaphragm Couplings

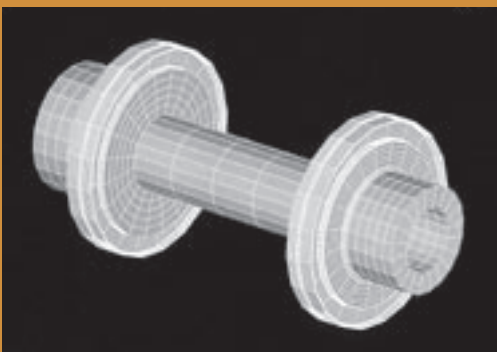

Contents

- 1 Introduction
- 2 Outline of Contoured Diaphragm Couplings
- 3 Advantages, Misalignment and Operating Principle
- 4 Numbering System and Construction
- 5 Selection Procedure
- 7 Model 66/Standard Dimensions and Characteristics
- 8 Diaphragm Type 304
- 9 Diaphragm Type 205·305·405·505
- 10 Diaphragm Type 206·306·406·506
- 11 Diaphragm Type 208·308·408·508
- 12 Diaphragm Type 210·310·410·510
- 13 Diaphragm Type 212·312·412·512
- 14 Diaphragm Type 214·314·414·514
- 15 Diaphragm Type 216·316·416·516
- 16 Diaphragm Type 318·418·518
- 17 Diaphragm Type 322·422·522
- 19 Model 67/74·99/100 Standard Dimensions and Characteristics
- 20 Model 67/74
- 22 Model 99/100
- 24 Multi Diaphragm
- 26 Special Connection to Equipment Shaft
- 27 Special Features
- 29 Test Equipment
- 30 Purchase Specification Form
- 32 Your Nearest EBI Representative



Tomorrow's plants will be.....

Larger machines:

Which require couplings lighter in weight and with smaller bearing load. Conventional couplings for larger torque transmission tend to create tremendous loads, both radial and axial directions, resulting in larger size of bearings, greater vibration and noise problems.

Higher speed machines:

Conventional couplings with parts which float from the rotating shaft have their limitations in maintaining dynamic balance. This causes many problems including vibrations and noise.

More sophisticated systems:

Which require more ingenious and periodical maintenance works. For such maintenance it is necessary to have an ample space and contemplate adequacy in terms of safety.

Demand for improvement of working conditions and clean engineering:

Plant operators should be free from the troubles and mess of oil and grease, so that they may concentrate their efforts on their principal works of operation and maintenance.

Oil-stained floor will no longer be a symbol of a plant.

More problems to maintain numbers of skilled operators:

Alignment which require skillfulness has been the most important factor for conventional coupling to determine their service life and machine vibration.

Contoured Diaphragm Couplings Will Solve All of The Above Problems



imum Performance
toured Daiphragm Couplings

Eagle Industry Co., Ltd has formed a worldwide alliance with Burgmann Industries GmbH & Co. since 2005. Contoured Diaphragm Couplings are manufactured by EagleBurgmann Japan. Contoured Diaphragm Couplings have been supplied for various high-speed/ high-torque applications such as compressors, turbines, etc. to help their successful operation, and as a result it is being highly evaluated by many users. Contoured Diaphragm Coupling features a maximum transmitting torque of 2700kNm, a maximum speed of 100,000rpm, non-lubrication and maintenance-free operation, which will surely contribute to various industries in their modernization and efficiency improvement efforts.

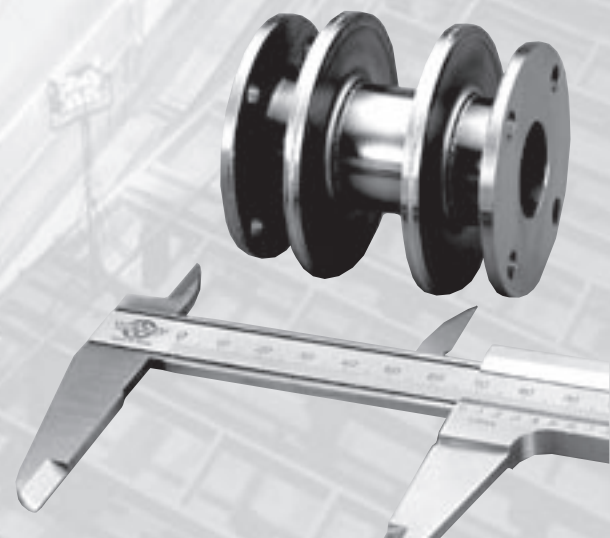

Advantages, Misalignments and Operating Principle

The Contoured Diaphragm Couplings are so designed that all misalignments of rotating shafts can be accommodated by elastic flexure of very thin web of the diaphragm. Flexibility both in bending and compression, and high torque transmissions are achieved by elastic deflections and torsional rigidity of the specially contoured diaphragms.

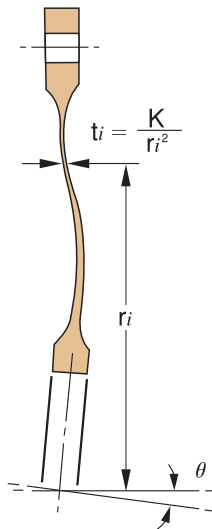

- Special diaphragm profile
 - High torque transmission
 - Low bearing load
 - Simple construction
 - Ease of installation and removal of "Spacer" (Flex unit)
 - Light weight
 - Permanent balance
 - No relative or rubbing movement of any parts
 - No lubrication
 - No vibration or noise generations
 - Zero backlash
- Best for high speed application (up to 100,000rpm)

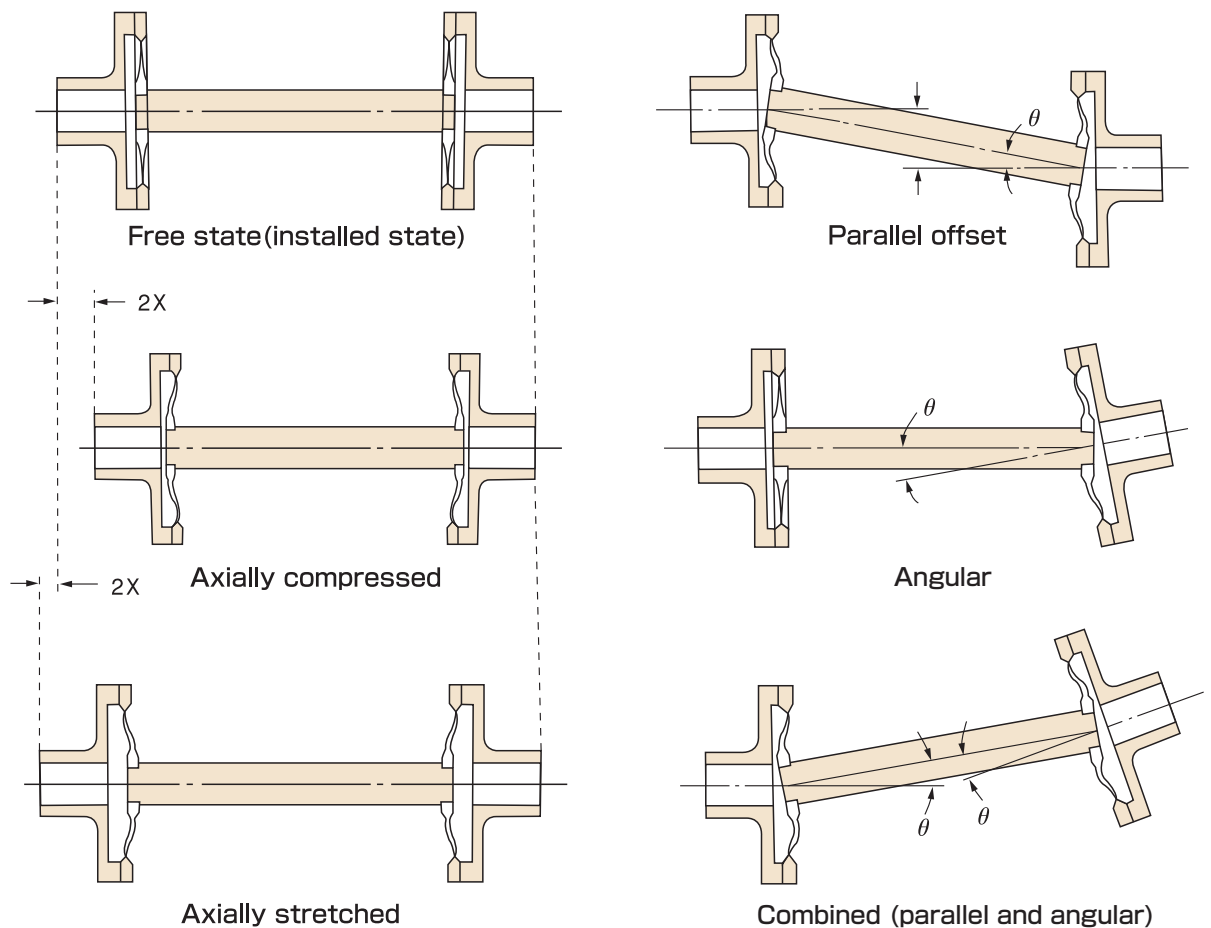

Numbering System and Construction

① Model Number
66, 67, 74, 99, 100

② Specific features

L : Model 66 Low Speed
I : Model 66 Middle Speed
H : Model 66 High Speed
E : Model 67, 74, 99, 100 Standard
S : Special Diaphragm
F : Integral Flange

M : Multi Diaphragm
P : Shear Pin
R : Electrically Insulated
T : Torque Monitoring System
B : Back-up Gear

③ Diaphragm Type

66 I-308-250-FG

④ Diaphragm series:

The diaphragms are available in five groups (2,3,4,5,6) per size in accordance with its flexibility.

⑤ Diaphragm size:

Standard 04,05,06,08,10,12,14,16,18,22
*Other sizes are available upon request.

⑥ Flex Unit length:

The Flex Unit length for each size shown in Characteristic Chart is our standard. Other lengths are available upon request.

⑦ Hubs:

Model 66 hubs are standardized with base bores. Standard hubs are identified as A~L and non-standard as Z.

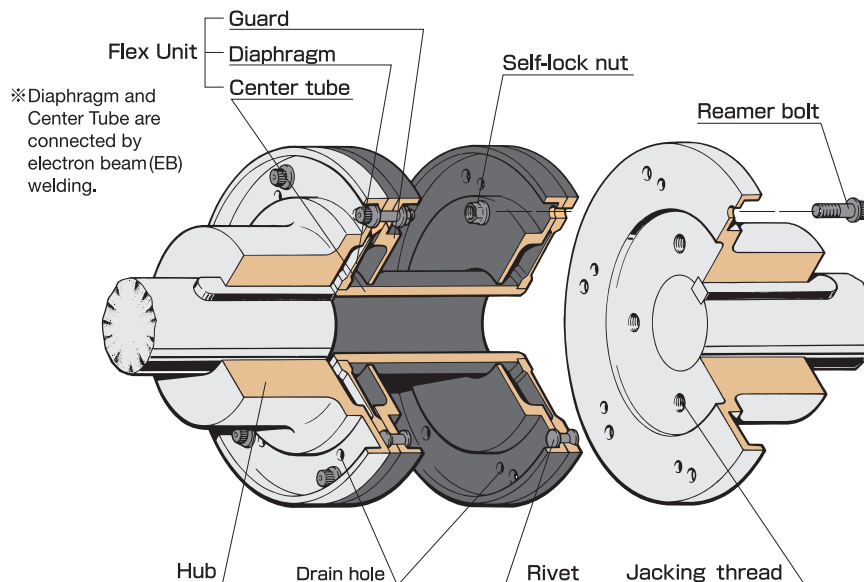

Selection Procedure

STEP 1

●Check Required Data

- Power (kW, PS, HP) and speed of the driver machine
- Required transmission torque (N-m) and service factor
- Shaft diameters of the driver and the driven where the hubs are connected and distance between the shaft ends

STEP 2

●Calculate Torque “T” (Nm)

$$T = \frac{9552 \times kW}{N} \times SF \qquad T = \frac{7121 \times HP}{N} \times SF \qquad T = \frac{7024 \times PS}{N} \times SF$$

◎Power : kW、HP、PS ◎Speed : N (rpm) ◎Service Factor : SE (For example API671 4th=1.5)

STEP 3

●Select Coupling Type

Select the coupling type from pages 8~17 or 20~23 so that the transmitting torque required is greater than or equal to the torque specified in Characteristic Chart.

*Verify that the misalignments of the application are within ranges specified.

*For applications where motor start-up or equipment fluctuating torque occurs, a fatigue analysis is required. Contact us for such an application.

STEP 4

●Check the Hub Bore

The maximum bore of the coupling selected should be greater than the shaft diameter.

STEP 5

●Check Balance

Dynamic balance is performed as per our standard shown below unless otherwise specified.

Model	66 L	66 I	66 H	67	74	99	100
Flex Unit only	×	○	○	As per standard or specification ※2 required by a customer			
Driver Side Hub	×	×	※1				
Driven Side Hub	×	×	※1				
Final assembly	×	×	※1				

※1. If the balancing of the completely assembled coupling is specified, the balance is performed on each hub and the complete assembly.

※2. If API 671 coupling is specified without any other requirements, the balance is conducted on each hub and the complete assembly.

Note) Unless otherwise requested, balancing tolerance for 66I/66H is as per JIS G2.5(ISO G2.5). Balancing tolerance for Model 67/74/99/100 is subject to applicable standard or customer's requirement.

Standard Materials

	Model 66	Model 67/99	Model 74/100
Hub	SCM435, S25C※1, or Equivalent	SCM435, SNCM439, or Equivalent	SCM435, SNCM439, or Equivalent
Diaphragm	Special Alloy Steel	Model67:Special Low Alloy Steel Model99:Special Stainless Steel	Model74 :Special Low Alloy Steel Model100:Special Stainless Steel
Guard	SS400, SPCC※1, or Equivalent	SS400 or Equivalent	SCM440 or Equivalent
Center Tube	SNCM439 or Equivalent	SNCM439 or Equivalent	SNCM439 or Equivalent
Shim		SUS304, SCM440, or Equivalent	SUS304, SCM440, or Equivalent
Reamer Bolt	Low Alloy Steel	Low Alloy Steel	Low Alloy Steel
Self-lock Nut	Low Alloy Steel or Stainless Steel	Stainless steel	Stainless steel

※1. Diaphragm size 04 only

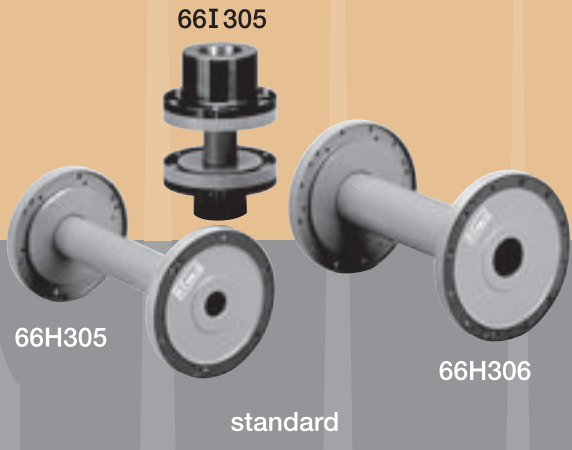

66I305

66H305

66H306

standard

Model **66**

CONTOURED DIAPHRAGM COUPLINGS

**Standard Dimensions and
Characteristics**

EagleBurgmann®

General Pumps
Machine Tools
General Machines

**Maximum Performance
Contoured Diaphragm Couplings**

Standard Dimensions and Characteristics

Model 66

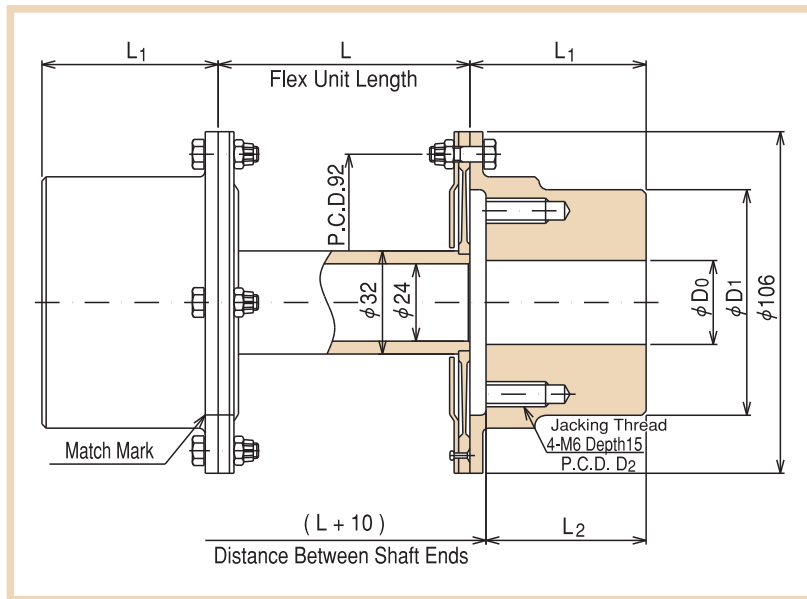

Numbering (Ex.)

66L304-150-AB



● Reamer Bolt Tightening Torque 6~7Nm

● Allowable Rotating Speed 4,000rpm

※ Contact us for speed exceeding 4,000rpm.

Dimension chart

Hub	Base bore D_0 mm	Max bore D mm	D_1 mm	D_2 mm	L_1 mm	L_2 mm	Mass kg	Inertia kg-cm ²
A	14	40	68	59	50	45	1.5	11.9
B	20	50	78	59	60	55	2.1	18.9

Characteristics Chart

Diaphragm Type	L mm	Transmitting Torque		Misalignment			Spring Rate			Unit Mass kg	Unit Inertia kg-cm ²
		Rated Nm	Limit Nm	Angular def. \pm rad	Parallel offset mm	Axial def. \pm mm	Angular def. Nm/rad	Axial def. N/mm	Torsional Nm/rad		
304	50	345	692	5.81×10^{-3}	0.27	1.34	217	126	5.97×10^4	0.60	8.29
	60				0.32				5.39×10^4	0.62	8.35
	70				0.38				4.92×10^4	0.65	8.40
	80				0.44				4.52×10^4	0.68	8.46
	90				0.50				4.18×10^4	0.71	8.51
	100				0.56				3.89×10^4	0.73	8.57
	110				0.61				3.64×10^4	0.76	8.62
	120				0.67				3.41×10^4	0.79	8.68
	130				0.73				3.22×10^4	0.82	8.73
	140				0.79				3.04×10^4	0.84	8.79
	150				0.85				2.88×10^4	0.87	8.84

Standard Dimensions and Characteristics

Model 66

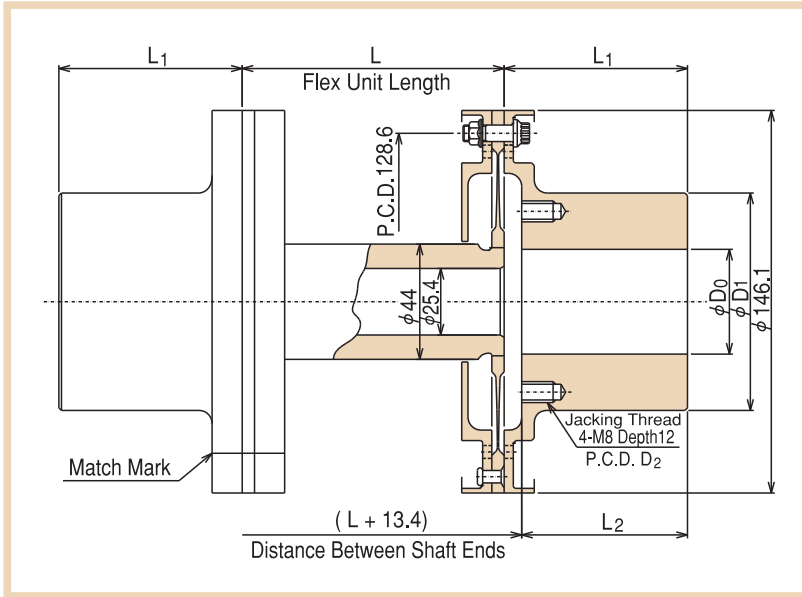

Numbering (Ex.)

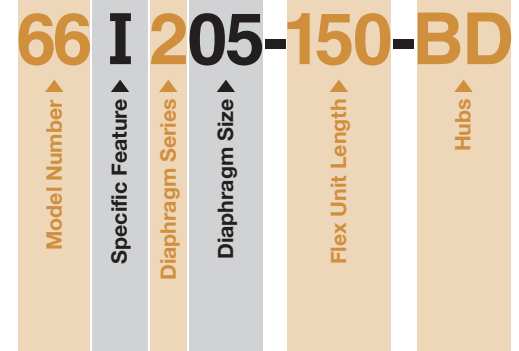

● Reamer Bolt Tightening Torque 10~12Nm

● Allowable Rotating Speed (rpm)

Speed Range	Diaphragm series			
	205	305	405	505
66 L	3,000	3,000	3,000	3,000
66 I	7,200	7,200	7,200	7,200
66 H	18,200	22,300	24,900	27,400

Dimension chart

Hub	Base bore Do mm	Max bore D mm	D1 mm	D2 mm	L1 mm	L2 mm	Mass kg	Inertia kg-cm ²
A	20	26	58	44	40	33.3	1.2	20.4
B	20	36	68	54	50	43.3	1.7	24.2
C	30	46	83	69	60	53.3	2.4	35.3
D	30	60	98	84	70	63.3	3.8	59.1

Characteristics Chart

Diaphragm Type	L mm	Transmitting Torque		Misalignment			Spring Rate			Unit Mass kg	Unit Inertia kg-cm ²
		Rated Nm	Limit Nm	Angular def. ±rad	Parallel offset mm	Axial def. ±mm	Angular def. Nm/rad	Axial def. N/mm	Torsional Nm/rad		
205	100	667	1,300	8.72×10 ⁻³	0.83	1.46	421	114	1.15×10 ⁵	2.4	57.7
	150				1.26				9.38×10 ⁴	2.8	59.0
	200				1.70				7.95×10 ⁴	3.2	60.3
	250				2.14				6.89×10 ⁴	3.6	61.5
	300				2.57				6.08×10 ⁴	4.0	62.8
	350				3.01				5.44×10 ⁴	4.4	64.1
	400				3.44				4.93×10 ⁴	4.8	65.4
	450				3.88				4.50×10 ⁴	5.2	66.7
305	100	1,000	3,390	5.81×10 ⁻³	0.55	0.97	1,420	386	1.35×10 ⁵	2.4	58.1
	150				0.84				1.07×10 ⁵	2.8	59.4
	200				1.13				8.87×10 ⁴	3.2	60.7
	250				1.42				7.58×10 ⁴	3.6	61.9
	300				1.71				6.61×10 ⁴	4.0	63.2
	350				2.00				5.86×10 ⁴	4.4	64.5
	400				2.29				5.27×10 ⁴	4.8	65.8
	450				2.59				4.78×10 ⁴	5.2	67.1
405	100	1,330	4,050	4.36×10 ⁻³	0.41	0.76	3,370	915	1.48×10 ⁵	2.4	58.5
	150				0.63				1.15×10 ⁵	2.8	59.8
	200				0.85				9.42×10 ⁴	3.2	61.0
	250				1.07				7.97×10 ⁴	3.6	62.3
	300				1.28				6.91×10 ⁴	4.0	63.6
	350				1.50				6.10×10 ⁴	4.4	64.9
	400				1.72				5.46×10 ⁴	4.8	66.2
	450				1.94				4.94×10 ⁴	5.2	67.5
505	100	1,670	4,050	3.49×10 ⁻³	0.33	0.62	6,580	1,790	1.57×10 ⁵	2.5	58.9
	150				0.50				1.21×10 ⁵	2.9	60.2
	200				0.68				9.78×10 ⁴	3.3	61.4
	250				0.85				8.23×10 ⁴	3.7	62.7
	300				1.03				7.10×10 ⁴	4.1	64.0
	350				1.20				6.25×10 ⁴	4.5	65.3
	400				1.37				5.58×10 ⁴	4.9	66.6
	450				1.55				5.04×10 ⁴	5.3	67.9

Contact us if misalignment or flex unit length is greater than the figure listed.

Contact us for application where the fluctuating torque occurs from motor drive or reciprocating equipment.

Standard Dimensions and Characteristics

Model 66

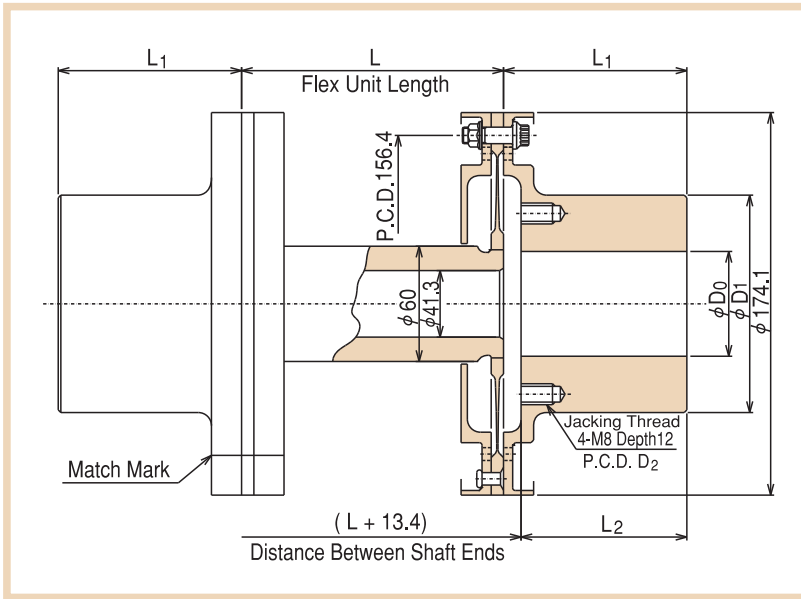

■Numbering(Ex.)

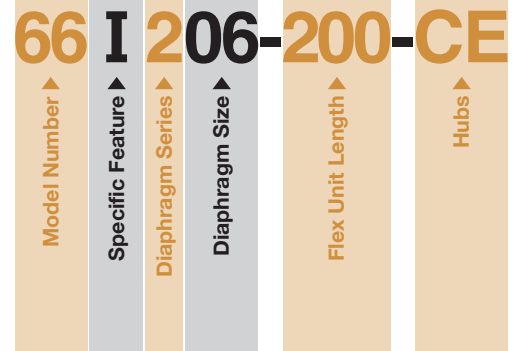

●Reamer Bolt Tightening Torque 10~12Nm

●Allowable Rotating Speed(rpm)

Speed Range	Diaphragm series			
	206	306	406	506
66 L	2,400	2,400	2,400	2,400
66 I	5,900	5,900	5,900	5,900
66 H	15,600	19,100	21,400	23,500

■Dimension chart

Hub	Base bore Do mm	Max bore D mm	D1 mm	D2 mm	L1 mm	L2 mm	Mass kg	Inertia kg-cm ²
B	30	36	68	54	50	43.3	1.8	42.6
C	30	46	83	69	60	53.3	2.7	54.0
D	30	60	98	84	70	63.3	4.1	77.8
E	30	75	118	104	80	73.3	6.4	138

■Characteristics Chart

Diaphragm Type	L mm	Transmitting Torque		Misalignment			Spring Rate			Unit Mass kg	Unit Inertia kg-cm ²
		Rated Nm	Limit Nm	Angular def. ±rad	Parallel offset mm	Axial def. ±mm	Angular def. Nm/rad	Axial def. N/mm	Torsional Nm/rad		
206	100	1,320	2,570	8.72×10 ⁻³	0.83	1.83	831	144	2.78×10 ⁵	3.3	114
	150				1.26				2.36×10 ⁵	3.9	118
	200				1.70				2.05×10 ⁵	4.5	122
	250				2.14				1.81×10 ⁵	5.0	125
	300				2.57				1.62×10 ⁵	5.6	129
	350				3.01				1.47×10 ⁵	6.2	133
	400				3.44				1.34×10 ⁵	6.8	137
	450				3.88				1.24×10 ⁵	7.4	141
306	100	1,970	6,710	5.81×10 ⁻³	0.55	1.22	2,800	484	3.40×10 ⁵	3.3	115
	150				0.84				2.80×10 ⁵	3.9	119
	200				1.13				2.37×10 ⁵	4.5	123
	250				1.42				2.06×10 ⁵	5.1	127
	300				1.71				1.82×10 ⁵	5.7	131
	350				2.00				1.63×10 ⁵	6.2	134
	400				2.29				1.48×10 ⁵	6.8	138
	450				2.59				1.35×10 ⁵	7.4	142
406	100	2,630	8,940	4.36×10 ⁻³	0.41	0.95	6,650	1,150	3.84×10 ⁵	3.4	116
	150				0.63				3.08×10 ⁵	4.0	120
	200				0.85				2.58×10 ⁵	4.5	124
	250				1.07				2.21×10 ⁵	5.1	128
	300				1.28				1.94×10 ⁵	5.7	132
	350				1.50				1.72×10 ⁵	6.3	136
	400				1.72				1.55×10 ⁵	6.9	140
	450				1.94				1.41×10 ⁵	7.5	143
506	100	3,290	8,980	3.49×10 ⁻³	0.33	0.78	13,000	2,240	4.16×10 ⁵	3.4	117
	150				0.50				3.28×10 ⁵	4.0	121
	200				0.68				2.71×10 ⁵	4.6	125
	250				0.85				2.31×10 ⁵	5.2	129
	300				1.03				2.02×10 ⁵	5.8	133
	350				1.20				1.79×10 ⁵	6.3	137
	400				1.37				1.60×10 ⁵	6.9	141
	450				1.55				1.45×10 ⁵	7.5	145

Contact us if misalignment or flex unit length is greater than the figure listed.

Contact us for application where the fluctuating torque occurs from motor drive or reciprocating equipment.

Standard Dimensions and Characteristics

Model 66

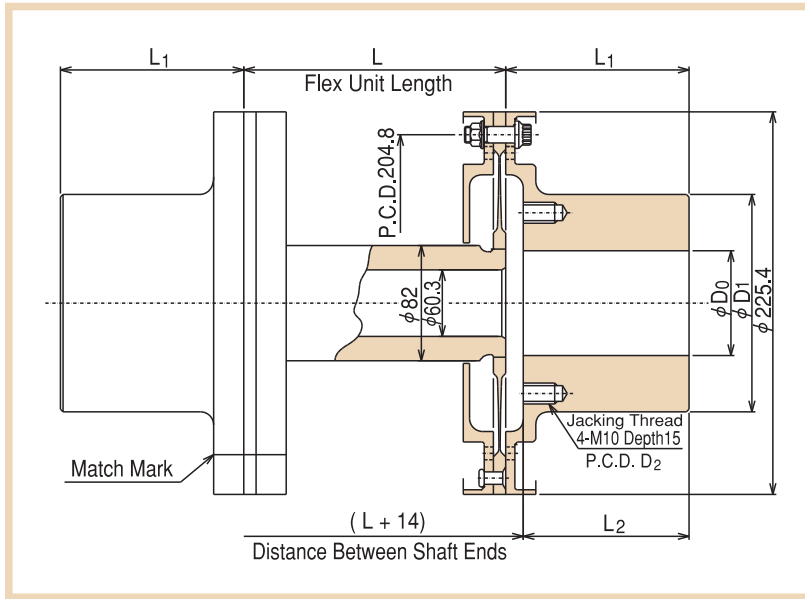

Numbering (Ex.)

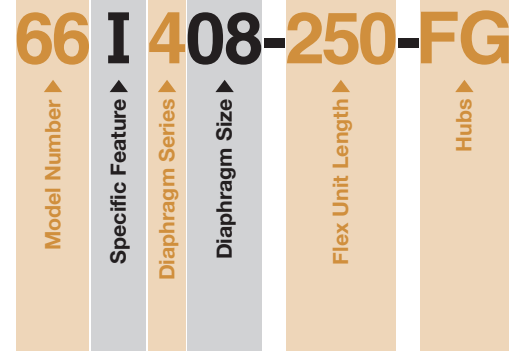

● Reamer Bolt Tightening Torque 20~23Nm

● Allowable Rotating Speed (rpm)

Speed Range	Diaphragm series			
	208	308	408	508
66 L	1,800	1,800	1,800	1,800
66 I	4,400	4,400	4,400	4,400
66 H	13,000	15,900	17,800	19,600

Dimension chart

Hub	Base bore Do mm	Max bore D mm	D1 mm	D2 mm	L1 mm	L2 mm	Mass kg	Inertia kg-cm ²
C	30	46	83	67	60	53	4.1	174
D	30	60	98	82	70	63	5.4	196
E	30	75	118	102	80	73	7.7	254
F	30	95	137	121	95	88	11.3	375
G	30	110	157	141	110	103	16.4	603

Characteristics Chart

Diaphragm Type	L mm	Transmitting Torque		Misalignment			Spring Rate			Unit Mass kg	Unit Inertia kg-cm ²
		Rated Nm	Limit Nm	Angular def. ±rad	Parallel offset mm	Axial def. ±mm	Angular def. Nm/rad	Axial def. N/mm	Torsional Nm/rad		
208	100	2,930	5,730	8.72×10 ⁻³	0.81	2.40	1,850	187	7.22×10 ⁵	5.8	356
	150				1.25				6.31×10 ⁵	6.8	368
	200				1.69				5.60×10 ⁵	7.7	381
	250				2.12				5.03×10 ⁵	8.7	393
	300				2.56				4.57×10 ⁵	9.6	405
	350				3.00				4.19×10 ⁵	10.6	418
	400				3.43				3.86×10 ⁵	11.5	430
	450				3.87				3.58×10 ⁵	12.5	442
308	100	4,400	14,900	5.81×10 ⁻³	0.54	1.60	6,250	633	9.20×10 ⁵	5.9	361
	150				0.83				7.77×10 ⁵	6.9	373
	200				1.12				6.72×10 ⁵	7.8	385
	250				1.41				5.92×10 ⁵	8.8	398
	300				1.70				5.29×10 ⁵	9.7	410
	350				2.00				4.78×10 ⁵	10.7	422
	400				2.29				4.36×10 ⁵	11.6	435
	450				2.58				4.01×10 ⁵	12.6	447
408	100	5,870	19,900	4.36×10 ⁻³	0.40	1.25	14,800	1,500	1.07×10 ⁶	6.0	365
	150				0.62				8.78×10 ⁵	7.0	378
	200				0.84				7.47×10 ⁵	7.9	390
	250				1.06				6.49×10 ⁵	8.9	402
	300				1.28				5.75×10 ⁵	9.8	415
	350				1.50				5.15×10 ⁵	10.8	427
	400				1.71				4.67×10 ⁵	11.7	439
	450				1.93				4.27×10 ⁵	12.7	452
508	100	7,330	22,800	3.49×10 ⁻³	0.32	1.02	28,900	2,930	1.18×10 ⁶	6.1	370
	150				0.50				9.53×10 ⁵	7.1	382
	200				0.67				8.00×10 ⁵	8.0	395
	250				0.85				6.89×10 ⁵	9.0	407
	300				1.02				6.06×10 ⁵	9.9	419
	350				1.20				5.40×10 ⁵	10.9	432
	400				1.37				4.87×10 ⁵	11.8	444
	450				1.54				4.44×10 ⁵	12.8	456

Contact us if misalignment or flex unit length is greater than the figure listed.

Contact us for application where the fluctuating torque occurs from motor drive or reciprocating equipment.

Standard Dimensions and Characteristics

Model 66

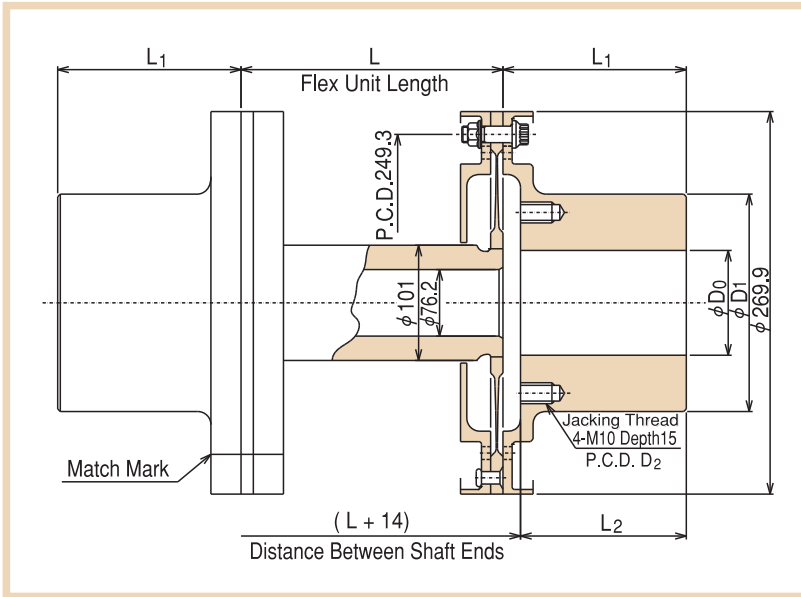

■Numbering(Ex.)

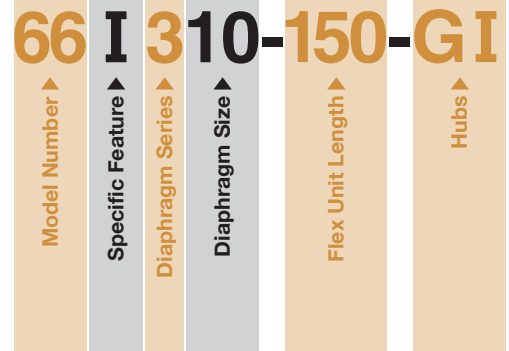

●Reamer Bolt Tightening Torque 20~23Nm

●Allowable Rotating Speed(rpm)

Speed Range	Diaphragm series			
	210	310	410	510
66 L	1,500	1,500	1,500	1,500
66 I	3,600	3,600	3,600	3,600
66 H	11,300	13,800	15,400	17,000

■Dimension chart

Hub	Base bore D_0 mm	Max bore D mm	D_1 mm	D_2 mm	L_1 mm	L_2 mm	Mass kg	Inertia kg-cm^2
E	50	75	118	102	80	73	8.0	415
F	50	95	137	121	95	88	11.4	535
G	50	110	157	141	110	103	16.4	763
H	50	125	177	161	125	118	23.0	1,150
I	90	140	197	181	140	133	26.9	1,710

■Characteristics Chart

Diaphragm Type	L mm	Transmitting Torque		Misalignment			Spring Rate			Unit Mass kg	Unit Inertia kg-cm^2
		Rated Nm	Limit Nm	Angular def. $\pm \text{rad}$	Parallel offset mm	Axial def. $\pm \text{mm}$	Angular def. Nm/rad	Axial def. N/mm	Torsional Nm/rad		
210	100	5,500	10,700	8.72×10^{-3}	0.80	2.95	3,470	231	1.43×10^6	8.8	790
	150				1.24				1.27×10^6	10.2	817
	200				1.67				1.13×10^6	11.5	844
	250				2.11				1.03×10^6	12.9	871
	300				2.54				9.40×10^5	14.2	898
	350				2.98				8.66×10^5	15.6	925
	400				3.42				8.02×10^5	16.9	952
	450				3.85				7.48×10^5	18.3	979
310	100	8,250	28,000	5.81×10^{-3}	0.53	1.97	11,700	780	1.85×10^6	9.0	803
	150				0.82				1.59×10^6	10.3	830
	200				1.11				1.39×10^6	11.7	857
	250				1.40				1.23×10^6	13.1	884
	300				1.69				1.11×10^6	14.4	911
	350				1.99				1.00×10^6	15.8	938
	400				2.28				9.20×10^5	17.1	965
	450				2.57				8.49×10^5	18.5	993
410	100	11,000	37,300	4.36×10^{-3}	0.40	1.55	27,800	1,850	2.17×10^6	9.2	816
	150				0.62				1.81×10^6	10.5	843
	200				0.83				1.56×10^6	11.9	870
	250				1.05				1.36×10^6	13.2	897
	300				1.27				1.21×10^6	14.6	924
	350				1.49				1.09×10^6	16.0	951
	400				1.71				9.92×10^5	17.3	979
	450				1.92				9.10×10^5	18.7	1,010
510	100	13,700	44,100	3.49×10^{-3}	0.32	1.26	54,200	3,610	2.43×10^6	9.4	829
	150				0.49				1.99×10^6	10.7	856
	200				0.67				1.68×10^6	12.1	883
	250				0.84				1.46×10^6	13.4	910
	300				1.01				1.29×10^6	14.8	938
	350				1.19				1.15×10^6	16.1	965
	400				1.36				1.04×10^6	17.5	992
	450				1.54				9.51×10^5	18.8	1,020

Contact us if misalignment or flex unit length is greater than the figure listed.

Contact us for application where the fluctuating torque occurs from motor drive or reciprocating equipment.

Standard Dimensions and Characteristics

Model 66

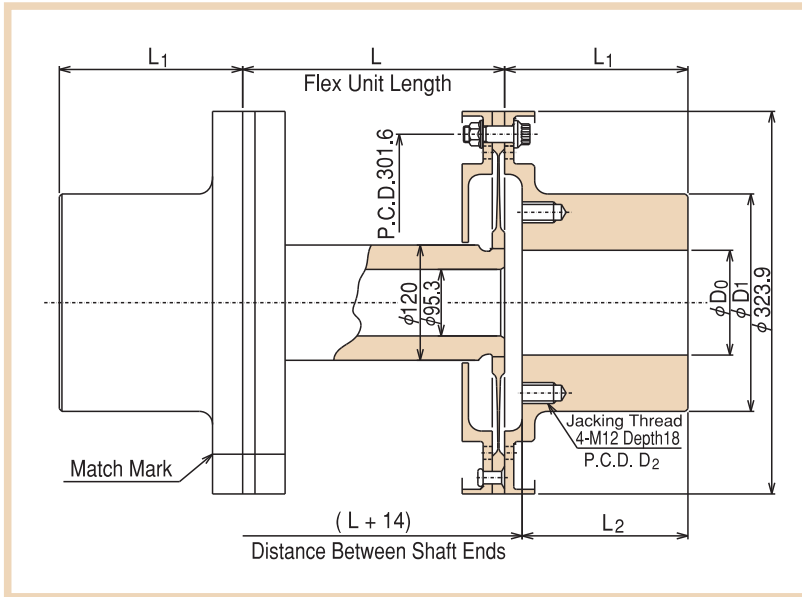

■ Numbering (Ex.)

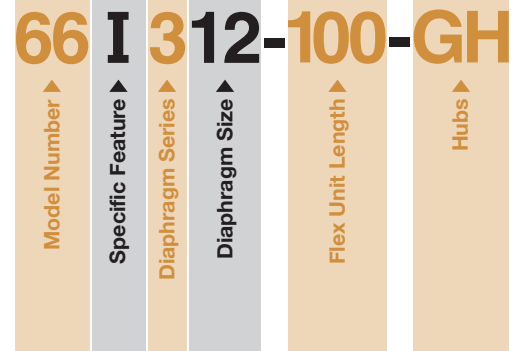

● Reamer Bolt Tightening Torque 20~23Nm

● Allowable Rotating Speed (rpm)

Speed Range	Diaphragm series			
	212	312	412	512
66 L	1,250	1,250	1,250	1,250
66 I	3,100	3,100	3,100	3,100
66 H	9,860	12,000	13,500	14,800

■ Dimension chart

Hub	Base bore D_0 mm	Max bore D mm	D_1 mm	D_2 mm	L_1 mm	L_2 mm	Mass kg	Inertia kg-cm^2
F	80	95	137	119	95	88	10.9	857
G	80	110	157	139	110	103	15.5	1,080
H	100	125	177	159	125	118	19.1	1,410
I	120	140	197	179	140	133	23.2	1,910
J	130	170	235	217	170	163	41.0	3,960

■ Characteristics Chart

Diaphragm Type	L mm	Transmitting Torque		Misalignment			Spring Rate			Unit Mass kg	Unit Inertia kg-cm^2
		Rated Nm	Limit Nm	Angular def. $\pm \text{rad}$	Parallel offset mm	Axial def. $\pm \text{mm}$	Angular def. Nm/rad	Axial def. N/mm	Torsional Nm/rad		
212	100	10,000	19,500	8.72×10^{-3}	0.79	3.60	6,330	282	2.55×10^6	12.9	1,740
	150				1.22				2.25×10^6	14.6	1,790
	200				1.66				2.02×10^6	16.2	1,840
	250				2.09				1.83×10^6	17.8	1,890
	300				2.53				1.67×10^6	19.5	1,940
	350				2.97				1.54×10^6	21.1	1,980
	400				3.40				1.43×10^6	22.8	2,030
	450				3.84				1.33×10^6	24.4	2,080
312	100	15,000	51,100	5.81×10^{-3}	0.52	2.42	21,400	953	3.27×10^6	13.3	1,780
	150				0.81				2.80×10^6	14.9	1,830
	200				1.10				2.45×10^6	16.5	1,880
	250				1.39				2.18×10^6	18.2	1,920
	300				1.69				1.96×10^6	19.8	1,970
	350				1.98				1.78×10^6	21.5	2,020
	400				2.27				1.63×10^6	23.1	2,070
	450				2.56				1.50×10^6	24.7	2,120
412	100	20,000	63,100	4.36×10^{-3}	0.39	1.88	50,600	2,260	3.82×10^6	13.6	1,820
	150				0.61				3.19×10^6	15.2	1,860
	200				0.83				2.74×10^6	16.9	1,910
	250				1.04				2.40×10^6	18.5	1,960
	300				1.26				2.14×10^6	20.2	2,010
	350				1.48				1.93×10^6	21.8	2,060
	400				1.70				1.75×10^6	23.4	2,100
	450				1.92				1.61×10^6	25.1	2,150
512	100	25,100	63,100	3.49×10^{-3}	0.31	1.54	98,900	4,410	4.25×10^6	13.9	1,850
	150				0.49				3.49×10^6	15.6	1,900
	200				0.66				2.96×10^6	17.2	1,950
	250				0.83				2.57×10^6	18.9	2,000
	300				1.01				2.27×10^6	20.5	2,040
	350				1.18				2.03×10^6	22.1	2,090
	400				1.36				1.84×10^6	23.8	2,140
	450				1.53				1.68×10^6	25.4	2,190

Contact us if misalignment or flex unit length is greater than the figure listed.

Contact us for application where the fluctuating torque occurs from motor drive or reciprocating equipment.

Standard Dimensions and Characteristics

Model 66

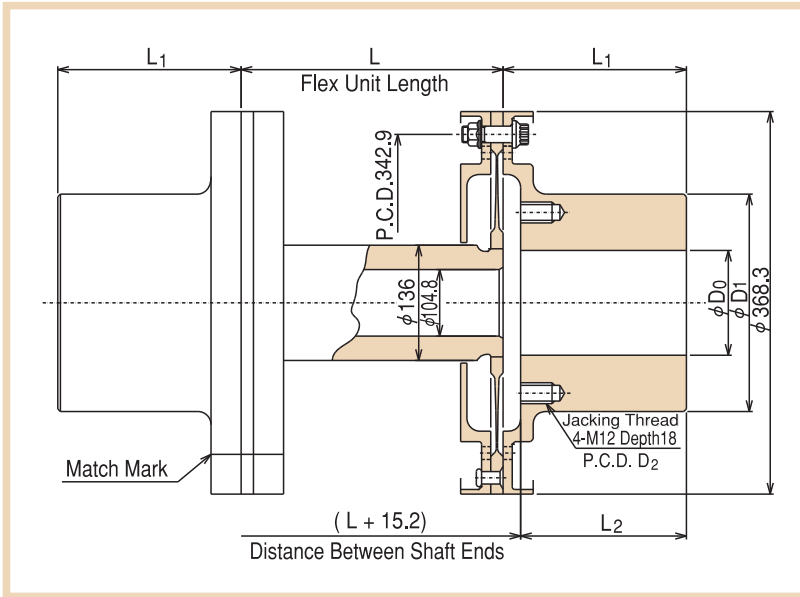

Numbering (Ex.)

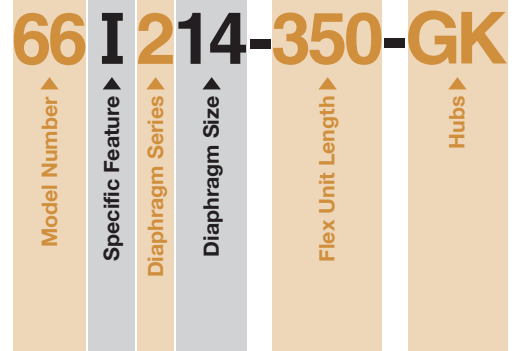

● Reamer Bolt Tightening Torque 34~38Nm

● Allowable Rotating Speed (rpm)

Speed Range	Diaphragm series			
	214	314	414	514
66 L	1,100	1,100	1,100	1,100
66 I	2,700	2,700	2,700	2,700
66 H	9,010	11,000	12,300	13,500

Dimension chart

Hub	Base bore Do mm	Max bore D mm	D1 mm	D2 mm	L1 mm	L2 mm	Mass kg	Inertia kg-cm ²
G	100	110	157	139	110	102.4	16.1	1,780
H	100	125	177	159	125	117.4	21.9	2,150
I	100	140	197	179	140	132.4	29.5	2,750
J	120	170	235	217	170	162.4	45.9	4,750
K	130	200	270	252	200	192.4	70.4	8,480

Characteristics Chart

Diaphragm Type	L mm	Transmitting Torque		Misalignment			Spring Rate			Unit Mass kg	Unit Inertia kg-cm ²		
		Rated Nm	Limit Nm	Angular def. ±rad	Parallel offset mm	Axial def. ±mm	Angular def. Nm/rad	Axial def. N/mm	Torsional Nm/rad				
214	100	14,900	29,100	8.72×10 ⁻³	0.77	4.12	9,420	322	4.00×10 ⁶	19.3	3,400		
	150				1.21				3.59×10 ⁶			21.6	3,480
	200				1.64				3.25×10 ⁶			23.9	3,570
	250				2.08				2.97×10 ⁶			26.2	3,650
	300				2.52				2.73×10 ⁶			28.5	3,740
	350				2.95				2.53×10 ⁶			30.8	3,820
	400				3.39				2.36×10 ⁶			33.1	3,910
	450				3.82				2.21×10 ⁶			35.5	3,990
314	100	22,400	76,000	5.81×10 ⁻³	0.51	2.76	31,800	1,090	5.23×10 ⁶	19.8	3,470		
	150				0.80				4.54×10 ⁶			22.1	3,550
	200				1.09				4.01×10 ⁶			24.4	3,640
	250				1.38				3.60×10 ⁶			26.7	3,720
	300				1.68				3.26×10 ⁶			29.0	3,810
	350				1.97				2.98×10 ⁶			31.3	3,890
	400				2.26				2.74×10 ⁶			33.7	3,980
	450				2.55				2.54×10 ⁶			36.0	4,060
414	100	29,800	101,000	4.36×10 ⁻³	0.38	2.16	75,400	2,580	6.18×10 ⁶	20.3	3,540		
	150				0.60				5.24×10 ⁶			22.6	3,620
	200				0.82				4.55×10 ⁶			24.9	3,710
	250				1.04				4.02×10 ⁶			27.2	3,790
	300				1.26				3.60×10 ⁶			29.5	3,880
	350				1.47				3.26×10 ⁶			31.8	3,960
	400				1.69				2.98×10 ⁶			34.2	4,050
	450				1.91				2.74×10 ⁶			36.5	4,130
514	100	37,300	104,000	3.49×10 ⁻³	0.30	1.77	147,000	5,040	6.94×10 ⁶	20.8	3,610		
	150				0.48				5.77×10 ⁶			23.1	3,690
	200				0.65				4.95×10 ⁶			25.4	3,780
	250				0.83				4.33×10 ⁶			27.7	3,860
	300				1.00				3.84×10 ⁶			30.0	3,950
	350				1.18				3.46×10 ⁶			32.3	4,030
	400				1.35				3.14×10 ⁶			34.7	4,120
	450				1.53				2.88×10 ⁶			37.0	4,200

Contact us if misalignment or flex unit length is greater than the figure listed.

Contact us for application where the fluctuating torque occurs from motor drive or reciprocating equipment.

Standard Dimensions and Characteristics

Model 66

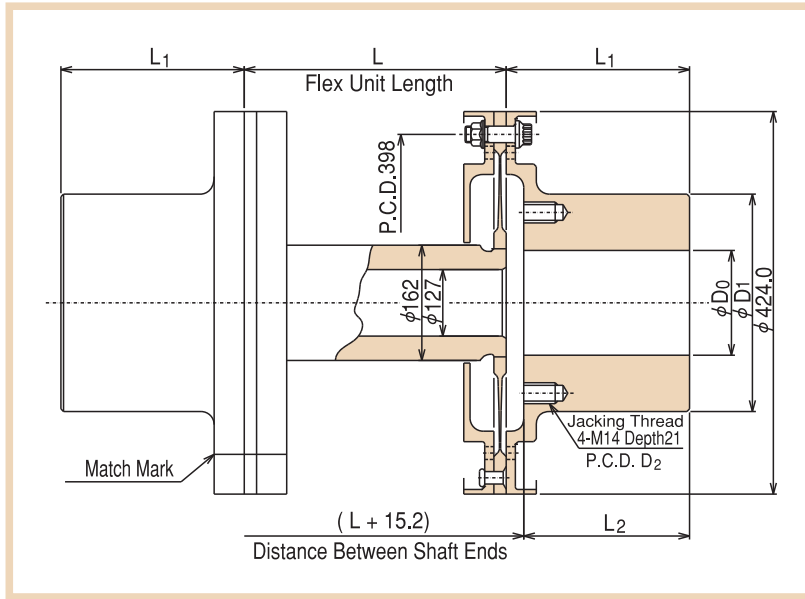

Numbering (Ex.)

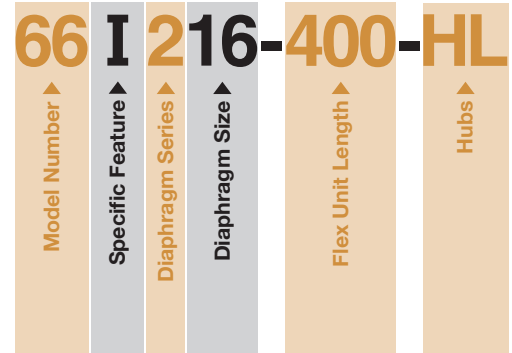

● Reamer Bolt Tightening Torque 34~38Nm

● Allowable Rotating Speed (rpm)

Speed Range	Diaphragm series			
	216	316	416	516
66 L	970	970	970	970
66 I	2,400	2,400	2,400	2,400
66 H	8,100	9,920	11,100	12,200

Dimension chart

Hub	Base bore Do mm	Max bore D mm	D1 mm	D2 mm	L1 mm	L2 mm	Mass kg	Inertia kg-cm ²
H	120	125	177	155	125	117.4	21.5	3,160
I	120	140	197	175	140	132.4	28.7	3,740
J	120	170	235	213	170	162.4	48.7	5,860
K	140	200	270	248	200	192.4	70.0	9,440
L	140	240	300	278	230	222.4	102.2	15,100

Characteristics Chart

Diaphragm Type	L mm	Transmitting Torque		Misalignment			Spring Rate			Unit Mass kg	Unit Inertia kg-cm ²		
		Rated Nm	Limit Nm	Angular def. ±rad	Parallel offset mm	Axial def. ±mm	Angular def. Nm/rad	Axial def. N/mm	Torsional Nm/rad				
216	100	23,900	46,600	8.72×10 ⁻³	0.76	4.82	15,100	377	6.72×10 ⁶	26.8	6,330		
	150				1.19				6.10×10 ⁶			29.9	6,490
	200				1.63				5.59×10 ⁶			33.0	6,660
	250				2.07				5.16×10 ⁶			36.1	6,820
	300				2.50				4.79×10 ⁶			39.3	6,990
	350				2.94				4.47×10 ⁶			42.4	7,150
	400				3.38				4.19×10 ⁶			45.5	7,320
	450				3.81				3.94×10 ⁶			48.6	7,480
316	100	35,800	121,000	5.81×10 ⁻³	0.50	3.21	50,800	1,270	8.92×10 ⁶	27.6	6,480		
	150				0.79				7.86×10 ⁶			30.7	6,650
	200				1.09				7.04×10 ⁶			33.8	6,810
	250				1.38				6.36×10 ⁶			36.9	6,980
	300				1.67				5.81×10 ⁶			40.1	7,140
	350				1.96				5.35×10 ⁶			43.2	7,310
	400				2.25				4.95×10 ⁶			46.3	7,470
	450				2.54				4.61×10 ⁶			49.4	7,640
416	100	47,700	162,000	4.36×10 ⁻³	0.38	2.51	121,000	3,020	1.07×10 ⁷	28.4	6,630		
	150				0.59				9.19×10 ⁶			31.5	6,800
	200				0.81				8.08×10 ⁶			34.6	6,960
	250				1.03				7.21×10 ⁶			37.7	7,130
	300				1.25				6.50×10 ⁶			40.9	7,290
	350				1.47				5.93×10 ⁶			44.0	7,460
	400				1.69				5.44×10 ⁶			47.1	7,620
	450				1.90				5.03×10 ⁶			50.2	7,790
516	100	59,600	170,000	3.49×10 ⁻³	0.30	2.05	235,000	5,890	1.21×10 ⁷	29.2	6,790		
	150				0.47				1.02×10 ⁷			32.3	6,950
	200				0.65				8.87×10 ⁶			35.4	7,120
	250				0.82				7.83×10 ⁶			38.6	7,280
	300				1.00				7.00×10 ⁶			41.7	7,450
	350				1.17				6.34×10 ⁶			44.8	7,610
	400				1.35				5.79×10 ⁶			47.9	7,780
	450				1.52				5.33×10 ⁶			51.0	7,940

Contact us if misalignment or flex unit length is greater than the figure listed.

Contact us for application where the fluctuating torque occurs from motor drive or reciprocating equipment.

Standard Dimensions and Characteristics

Model 66

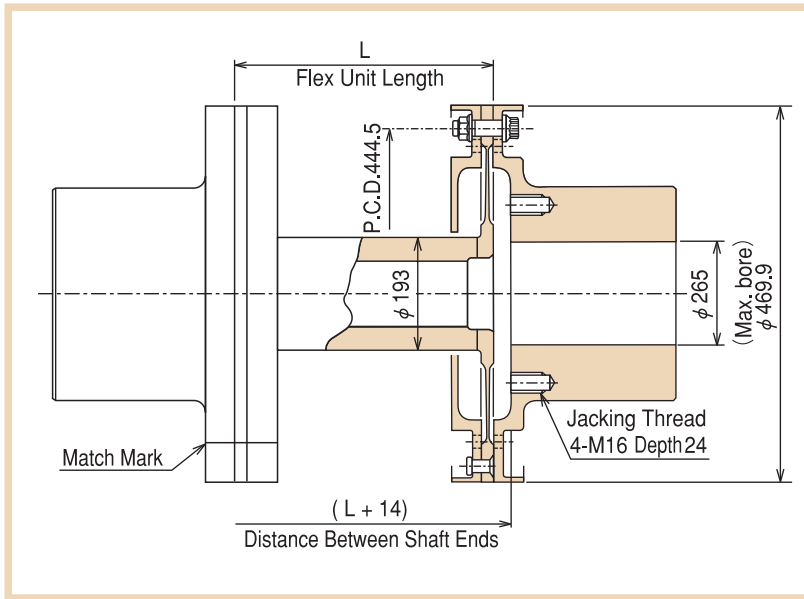

■ Numbering (Ex.)

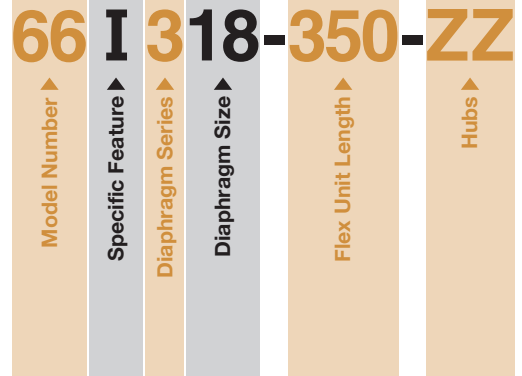

● Reamer Bolt Tightening Torque 34~38Nm

● Allowable Rotating Speed (rpm)

Speed Range	Diaphragm series		
	318	418	518
66 I	2,100	2,100	2,100
66 H	9,280	10,300	11,400

■ Characteristics Chart

Diaphragm Type	L mm	Transmitting Torque		Misalignment			Spring Rate			Unit Mass kg	Unit Inertia kg-cm ²
		Rated Nm	Limit Nm	Angular def. ±rad	Parallel offset mm	Axial def. ±mm	Angular def. Nm/rad	Axial def. N/mm	Torsional Nm/rad		
318	200	48,100	163,000	5.81×10^{-3}	1.09	3.54	68,300	1,400	1.08×10^7	42.4	11,500
	400				2.25				7.84×10^6		
	600				3.42				6.15×10^6		
	800				4.58				5.06×10^6		
	1,000				5.74				4.30×10^6		
	1,200				6.91				3.73×10^6		
418	200	64,100	217,000	4.36×10^{-3}	0.82	2.80	162,000	3,330	1.27×10^7	43.5	11,800
	400				1.69				8.78×10^6		
	600				2.56				6.71×10^6		
	800				3.43				5.43×10^6		
	1,000				4.31				4.56×10^6		
	1,200				5.18				3.93×10^6		
518	200	80,100	272,000	3.49×10^{-3}	0.64	2.27	316,000	6,500	1.63×10^7	52.2	13,200
	400				1.34				1.13×10^7		
	600				2.03				8.66×10^6		
	800				2.73				7.01×10^6		
	1,000				3.43				5.89×10^6		
	1,200				4.13				5.08×10^6		

Contact us if misalignment or flex unit length is greater than the figure listed.

Contact us for application where the fluctuating torque occurs from motor drive or reciprocating equipment.

Standard Dimensions and Characteristics

Model 66

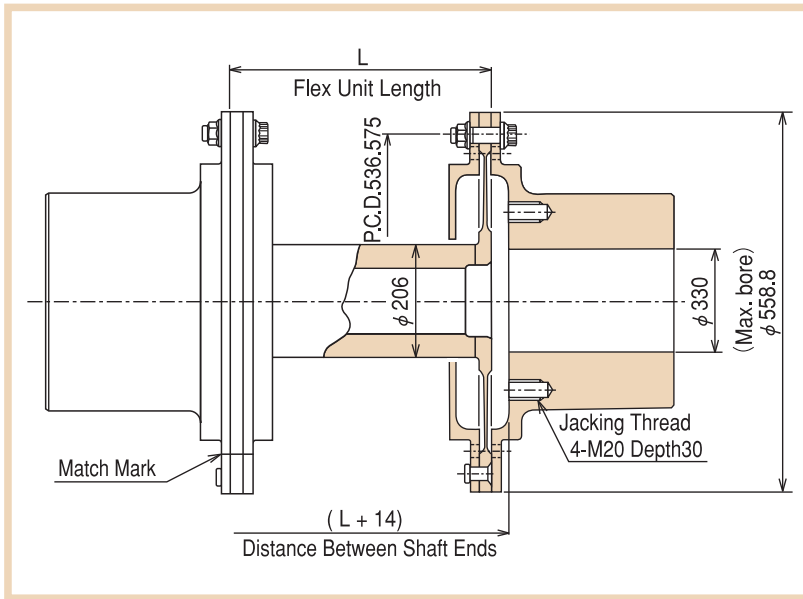

■Numbering(Ex.)

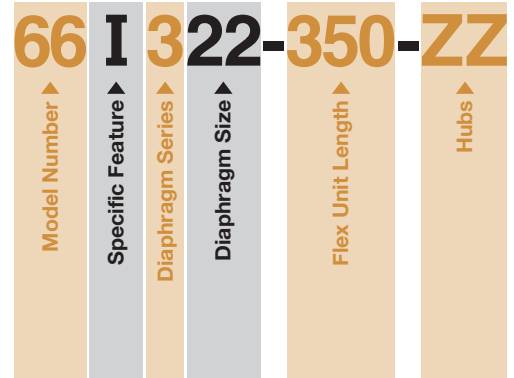

● Reamer Bolt Tightening Torque 34~38Nm

● Allowable Rotating Speed(rpm)

Speed Range	Diaphragm series		
	322	422	522
66 I	2,000	2,000	2,000
66 H	8,010	8,970	9,870

■Characteristics Chart

Diaphragm Type	L mm	Transmitting Torque		Misalignment			Spring Rate			Unit Mass kg	Unit Inertia kg-cm ²		
		Rated Nm	Limit Nm	Angular def. ±rad	Parallel offset mm	Axial def. ±mm	Angular def. Nm/rad	Axial def. N/mm	Torsional Nm/rad				
322	200	91,900	312,000	5.81×10^{-3}	1.07	4.80	116,000	1,560	1.77×10^7	65.1	23,000		
	400				2.23				1.30×10^7			88.5	24,900
	600				3.39				1.03×10^7			112.0	26,800
	800				4.56				8.47×10^6			135.5	28,800
	1,000				5.72				7.22×10^6			158.9	30,700
	1,200				6.88				6.29×10^6			182.4	32,600
422	200	123,000	416,000	4.36×10^{-3}	0.80	3.75	276,000	3,700	2.09×10^7	67.6	23,800		
	400				1.67				1.46×10^7			91.1	25,700
	600				2.54				1.13×10^7			114.5	27,600
	800				3.42				9.15×10^6			138.0	29,600
	1,000				4.29				7.70×10^6			161.5	31,500
	1,200				5.16				6.65×10^6			184.9	33,400
522	200	153,000	520,000	3.49×10^{-3}	0.63	3.06	538,000	7,220	2.61×10^7	78.8	25,000		
	400				1.32				1.81×10^7			110.6	27,300
	600				2.02				1.39×10^7			142.4	29,700
	800				2.72				1.12×10^7			174.2	32,000
	1,000				3.42				9.45×10^6			206.0	34,400
	1,200				4.12				8.15×10^6			237.8	36,700

Contact us if misalignment or flex unit length is greater than the figure listed.

Contact us for application where the fluctuating torque occurs from motor drive or reciprocating equipment.

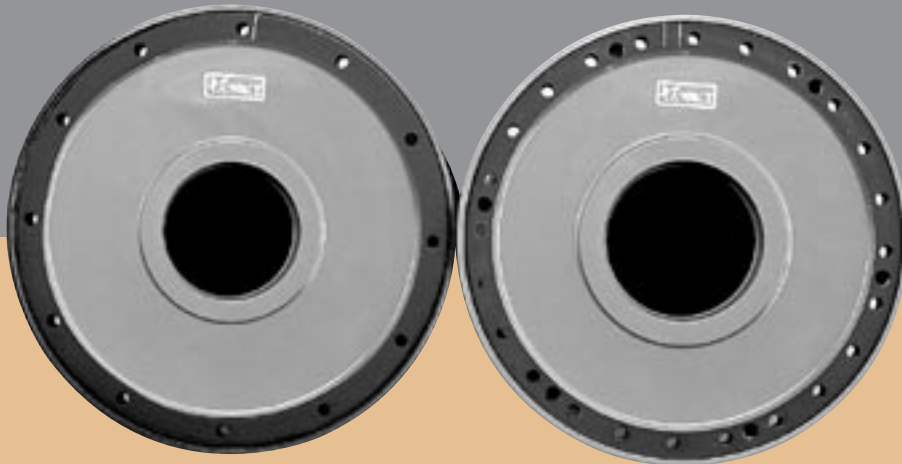
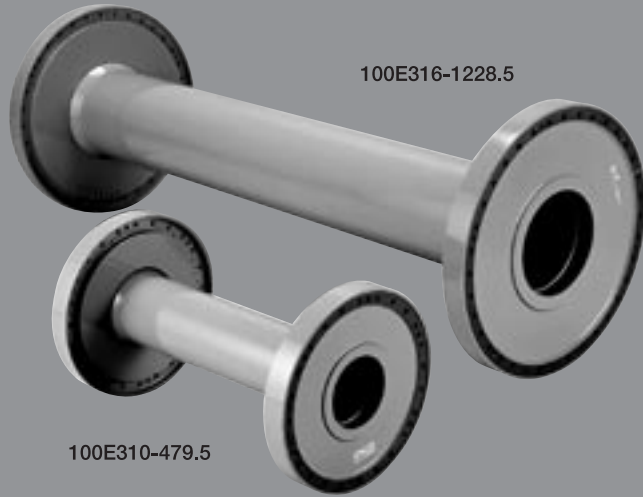

MODEL74

MODEL100

MODEL67
MODEL99

MODEL74
MODEL100

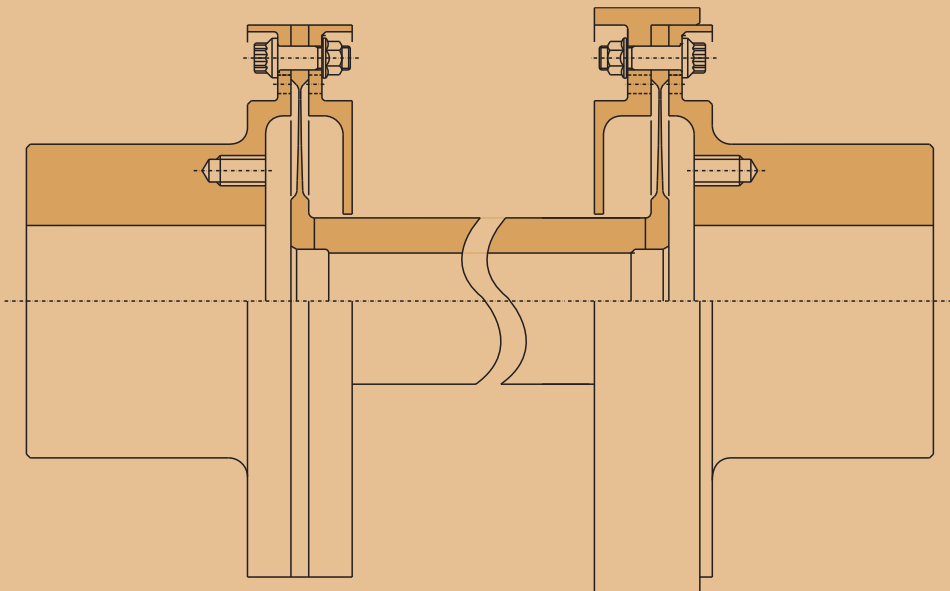

API671 Couplings
High Speed and High Torque Applications

Model **67/74**

Model **99/100**

CONTOURED DIAPHRAGM COUPLINGS

**Standard Dimensions and
Characteristics**

EagleBurgmann®

Gas Turbines
Steam Turbines
Compressors

**Maximum Performance
Contoured Diaphragm Couplings**

API671 Couplings

- Model 67/99 – Low speed application
The hubs and flex unit are centered by the reamer bolts.
- Model 74/100 – High speed application
The hubs and flex unit are centered by means of piloted guard. The hub and flex unit O.D. and the piloted guard I.D. are interference fitted for easy alignment.

Diaphragm Materials

Model 67/74 – Special alloy steel

Model 99/100 – Special precipitation hardened stainless steel

Model 99/100 couplings

Compared to the model 67/74, they offer:

- ♦ Greater allowable maximum continuous torque in the same diaphragm
- ♦ Reduced diaphragm size and reduced moment
- ♦ Increased corrosion protection

Standard Dimensions and Characteristics

Model 67/74

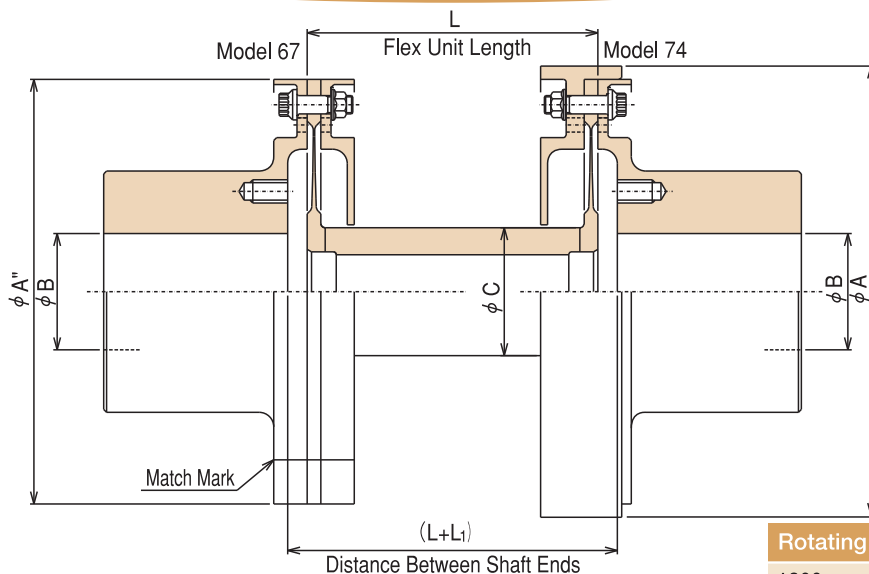

Rotating Speed	Model
1800rpm or lower	67
Higher than 1800rpm	74

For API671 Compliance

Characteristics Chart

Diaphragm Type	67/74 L ^{*1} mm	Transmitting Torque		Misalignment ^{*2}			Limit ^{*4} Speed rpm	Coupling OD φA ^{*5} mm	Max bore φB ^{*6} mm	Tube OD φC mm	L1 mm
		Rated Nm	Limit Nm	Angular def. ±rad	Parallel offset mm	Axial def. ±mm					
305	100/180 1,250	1,500	3,400	4.36×10 ⁻³	※3	1.60	34,000	155.2	70	44	14
405		2,000	4,530	3.49×10 ⁻³		1.24	39,000				
505		2,500	5,660	2.90×10 ⁻³		1.01	44,000				
605		3,000	6,800	2.49×10 ⁻³		0.85	48,000				
306	100/180 1,250	2,960	6,710	4.36×10 ⁻³	※3	1.91	29,000	183.2	85	60	14
406		3,950	8,950	3.49×10 ⁻³		1.50	33,000				
506		4,930	11,100	2.90×10 ⁻³		1.23	37,000				
606		5,920	13,400	2.49×10 ⁻³		1.05	41,000				
308	100/180 1,250	6,600	14,900	4.36×10 ⁻³	※3	2.54	24,000	234.6	120	82	14
408		8,800	19,900	3.49×10 ⁻³		1.99	28,000				
508		11,000	24,900	2.90×10 ⁻³		1.63	31,000				
608		13,200	29,900	2.49×10 ⁻³		1.38	34,000				
310	150/240 1,250	12,400	28,000	4.36×10 ⁻³	※3	2.95	21,000	279.0	150	101	14
410		16,500	37,300	3.49×10 ⁻³		2.35	24,000				
510		20,600	46,700	2.90×10 ⁻³		1.95	27,000				
610		24,700	56,000	2.49×10 ⁻³		1.66	30,000				
312	150/240 1,250	22,500	51,100	4.36×10 ⁻³	※3	3.84	18,000	333.0	185	120	14
412		30,100	68,100	3.49×10 ⁻³		3.01	21,000				
512		37,600	85,200	2.90×10 ⁻³		2.47	23,000				
612		45,100	102,000	2.49×10 ⁻³		2.09	26,000				
314	150/240 1,250	33,600	76,100	4.36×10 ⁻³	※3	4.23	16,000	377.4	210	136	14
414		44,800	101,000	3.49×10 ⁻³		3.35	19,000				
514		55,900	126,000	2.90×10 ⁻³		2.76	21,000				
614		67,100	152,000	2.49×10 ⁻³		2.35	24,000				

Standard Dimensions and Characteristics

Model 67/74

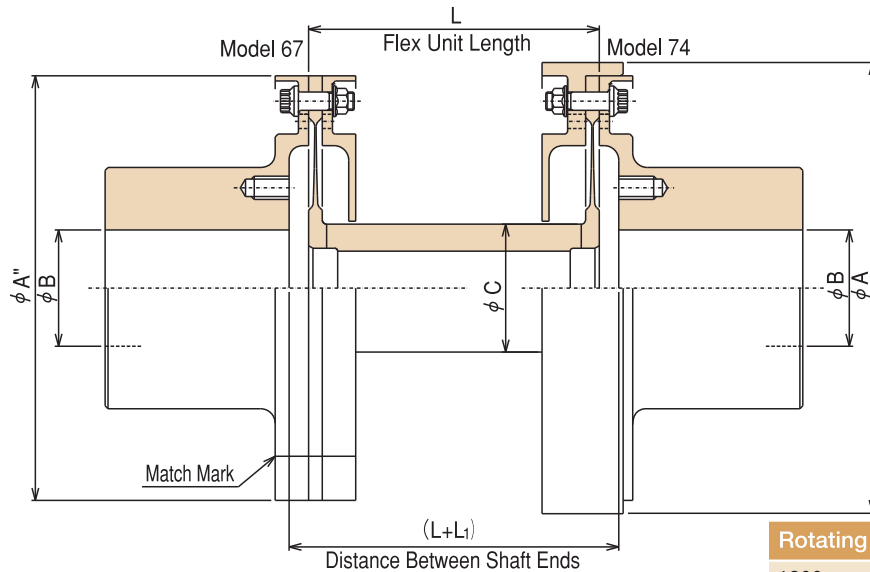

Rotating Speed	Model
1800rpm or lower	67
Higher than 1800rpm	74

For API671 Compliance

Diaphragm Type	67/74 L ^{※1} mm	Transmitting Torque		Misalignment ^{※2}			Limit ^{※4} Speed rpm	Coupling OD φA ^{※5} mm	Max bore φB ^{※6} mm	Tube OD φC mm	L1 mm
		Rated Nm	Limit Nm	Angular def. ±rad	Parallel offset mm	Axial def. ±mm					
316	150/240 1,250	53,700	121,000	4.36×10 ⁻³	※3	4.69	15,000	433.1	245	162	14
416		71,600	162,000	3.49×10 ⁻³		3.77	17,000				
516		89,500	202,000	2.90×10 ⁻³		3.14	19,000				
616		107,000	243,000	2.49×10 ⁻³		2.68	21,000				
318	200/300 1,250	72,100	163,000	4.36×10 ⁻³	※3	4.97	14,000	479.4	265	193	14
418		96,200	218,000	3.49×10 ⁻³		4.04	16,000				
518		120,000	272,000	2.90×10 ⁻³		3.39	18,000				
618		144,000	327,000	2.49×10 ⁻³		2.90	20,000				
322	200/300 1,250	138,000	312,000	4.36×10 ⁻³	※3	7.65	12,000	568.3	330	206	14
422		184,000	416,000	3.49×10 ⁻³		5.99	14,000				
522		230,000	521,000	2.90×10 ⁻³		4.91	15,000				
622		276,000	625,000	2.49×10 ⁻³		4.16	17,000				

※1 Contact us if the Flex Unit length required is beyond its range specified.

※2 Contact us if the misalignment required is higher than listed.

※3 The allowable parallel offset is determined by equation:

$$L \times \tan \theta$$

Where

L is a flex unit length (mm)

θ is an angular deflection (deg)

※4 The limit speed listed is at an axial deflection of ±0mm.

※5 The coupling OD (φA) shows the outside diameter of Model 74. For that of Model 67 (φA"), it is calculated by equation:

$$\phi A - 9.1$$

※6 The value listed shows the maximum bore diameter for each coupling type. Contact us if the shaft dimension is greater than that.

The hub is custom made so advise us of its dimension.

Standard Dimensions and Characteristics

Model 99/100

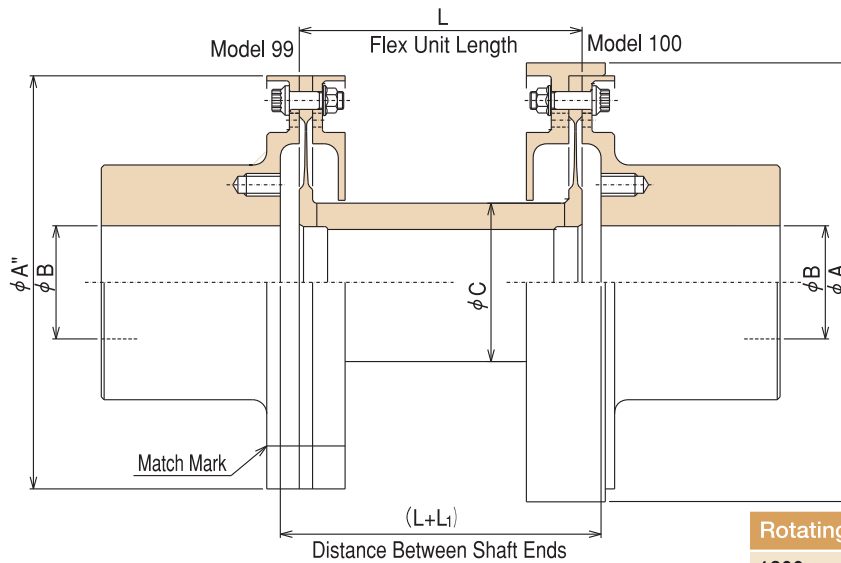

Rotating Speed	Model
1800rpm or lower	99
Higher than 1800rpm	100

For API671 Compliance

Characteristics Chart

Diaphragm Type	99/100 L ^{*1} mm	Transmitting Torque		Misalignment ^{*2}			Limit ^{*4} Speed rpm	Coupling OD φA ^{*5} mm	Max bore φB ^{*6} mm	Tube OD φC mm	L1 mm
		Rated Nm	Peak Nm	Angular def. ±rad	Parallel offset mm	Axial def. ±mm					
305	100/180 1,250	3,280	4,350	5.81×10 ⁻³	※3	1.24	35,000	155.2	70	55.6	14
405		4,290	5,690	4.36×10 ⁻³		1.01	40,000				
505		5,420	7,200	3.49×10 ⁻³		0.81	45,000				
605		6,550	8,700	2.90×10 ⁻³		0.66	50,000				
306	100/180 1,250	6,430	8,550	5.81×10 ⁻³	※3	1.52	28,000	183.2	85	71	14
406		8,580	11,300	4.36×10 ⁻³		1.19	33,000				
506		10,700	14,100	3.49×10 ⁻³		1.01	38,000				
606		12,800	17,000	2.90×10 ⁻³		0.83	43,000				
308	100/180 1,250	14,300	19,000	5.81×10 ⁻³	※3	1.91	23,000	234.6	120	96.5	14
408		19,100	25,300	4.36×10 ⁻³		1.60	28,000				
508		23,900	31,700	3.49×10 ⁻³		1.29	33,000				
608		27,700	36,700	2.90×10 ⁻³		1.19	35,000				
310	150/240 1,250	26,900	35,600	5.81×10 ⁻³	※3	2.18	20,000	279.0	150	119.5	14
410		35,800	47,500	4.36×10 ⁻³		1.82	25,000				
510		44,800	59,500	3.49×10 ⁻³		1.47	28,000				
610		53,900	71,600	2.90×10 ⁻³		1.27	30,000				
312	150/240 1,250	49,100	65,300	5.81×10 ⁻³	※3	2.66	19,000	333.0	185	148.5	14
412		65,500	87,000	4.36×10 ⁻³		2.20	22,000				
512		81,900	108,000	3.49×10 ⁻³		1.85	25,000				
612		98,100	130,000	2.90×10 ⁻³		1.57	27,000				
314	150/240 1,250	73,000	96,900	5.81×10 ⁻³	※3	2.92	17,000	377.4	210	168.9	14
414		97,300	128,000	4.36×10 ⁻³		2.46	20,000				
514		122,000	160,000	3.49×10 ⁻³		2.05	23,000				
614		146,000	194,000	2.90×10 ⁻³		1.72	25,000				

Standard Dimensions and Characteristics

Model 99/100

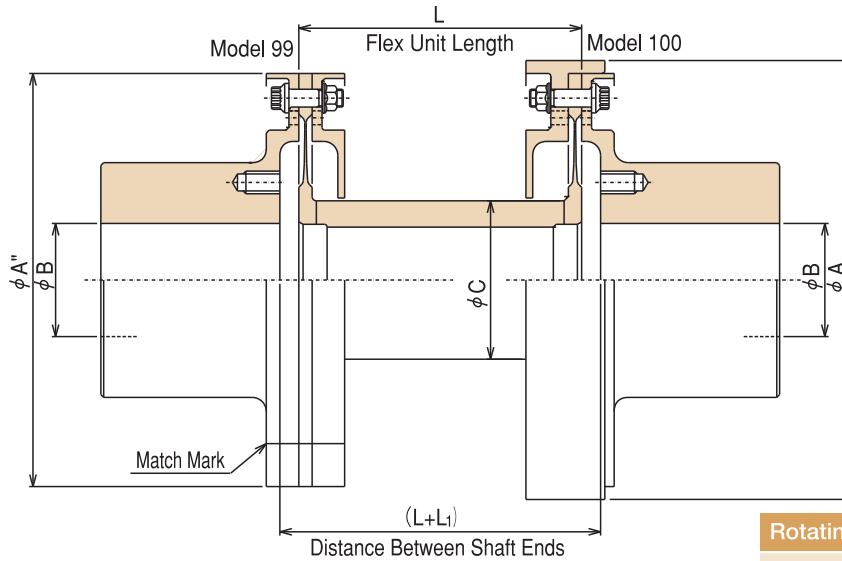

Rotating Speed	Model
1800rpm or lower	99
Higher than 1800rpm	100

For API671 Compliance

Diaphragm Type	99/100 L ^{*1} mm	Transmitting Torque		Misalignment ^{*2}			Limit ^{*4} Speed rpm	Coupling OD ϕA ^{*5} mm	Max bore ϕB ^{*6} mm	Tube OD ϕC mm	L1 mm
		Rated Nm	Peak Nm	Angular def. \pm rad	Parallel offset mm	Axial def. \pm mm					
316	150/240 1,250	116,000	152,000	5.81×10^{-3}	*3	3.20	15,000	433.1	245	199.4	14
416		155,000	205,000	4.36×10^{-3}		2.71	17,000				
516		194,000	257,000	3.49×10^{-3}		2.28	20,000				
616		232,000	308,000	2.90×10^{-3}		1.93	22,000				
318	200/300 1,250	157,000	207,000	5.81×10^{-3}	*3	3.75	14,000	479.4	265	222.3	14
418		210,000	278,000	4.36×10^{-3}		3.17	16,000				
518		262,000	348,000	3.49×10^{-3}		2.69	19,000				
618		314,000	416,000	2.90×10^{-3}		2.31	21,000				
322	200/300 1,250	299,000	397,000	5.81×10^{-3}	*3	4.36	12,000	568.3	330	279.3	14
422		399,000	530,000	4.36×10^{-3}		3.75	14,000				
522		499,000	662,000	3.49×10^{-3}		3.25	16,000				
622		599,000	796,000	2.90×10^{-3}		2.74	19,000				

*1 Contact us if the Flex Unit length required is beyond its range specified.

*2 Contact us if the misalignment required is higher than listed.

*3 The allowable parallel offset is determined by equation:

$$L \times \tan \theta$$

Where

L is a flex unit length (mm)

θ is an angular deflection (deg)

*4 The limit speed listed is at an axial deflection of ± 0 mm.

*5 The coupling OD (ϕA) shows the outside diameter of Model 100. For that of Model 99 ($\phi A''$), it is calculated by equation:

$$\phi A - 9.1$$

*6 The value listed shows the maximum bore diameter for each coupling type. Contact us if the shaft dimension is greater than that.

The hub is custom made so advise us of its dimension.

Multi Diaphragm

With two diaphragms installed at one side, absorption of misalignment (axial and angular displacement) can be double the case of one diaphragm.

O.D. Bolted

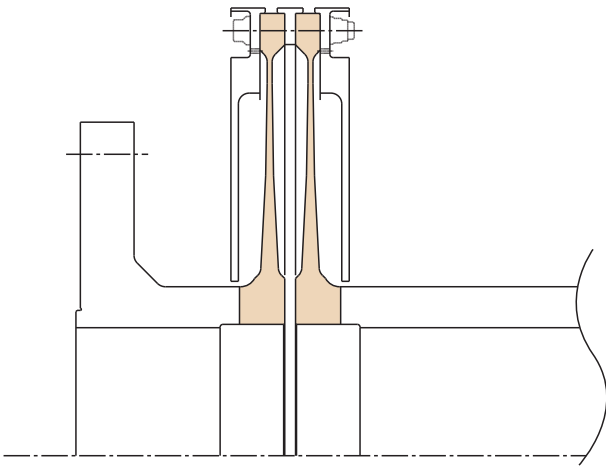

I.D. Welded

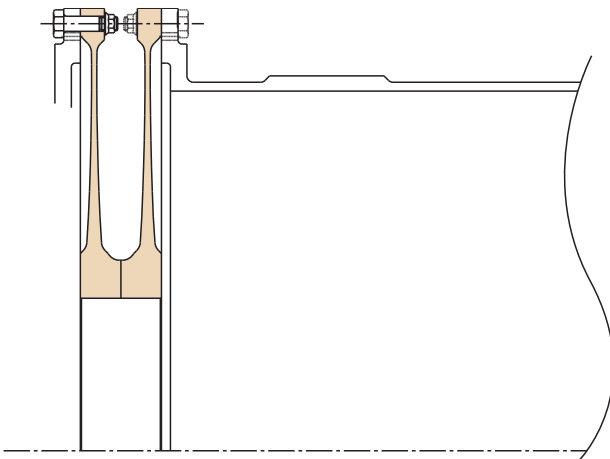

3 Diaphragms

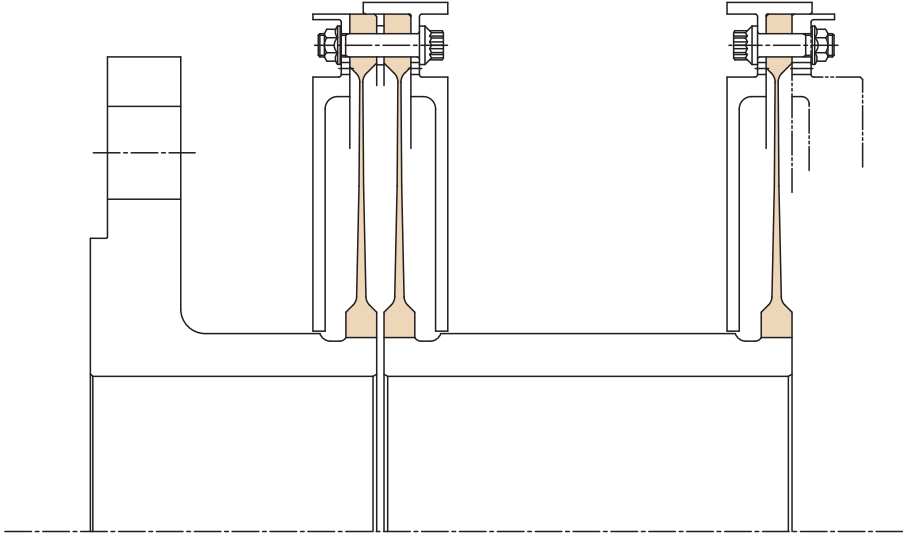

8 Diaphragms

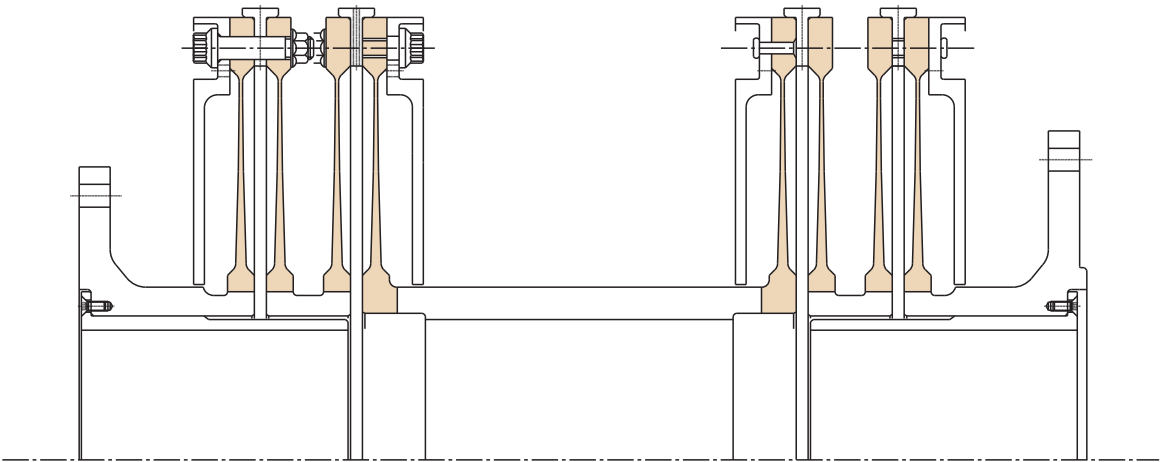

Special Connection to Equipment Shaft

These are the examples of direct connection to the flex unit or connection through the integral flange in case the equipment shaft end is flanged.

Direct Shaft

Direct Connection
Example 1

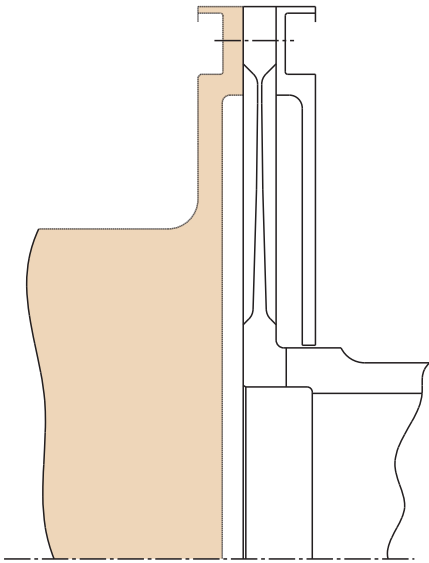

Direct Shaft

Direct Connection
Example 2

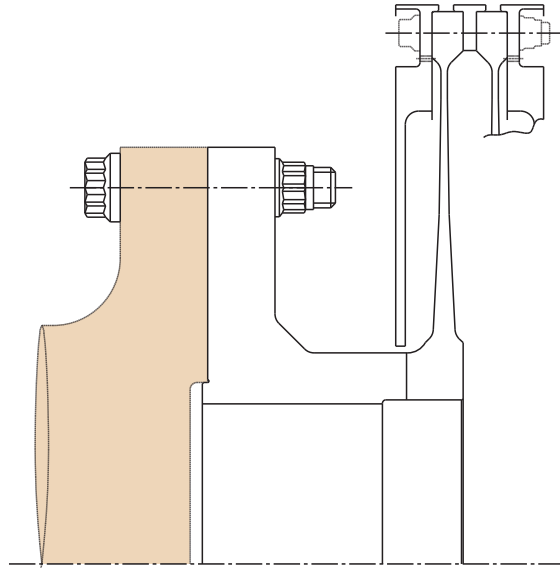

Integral Flange

Example 1

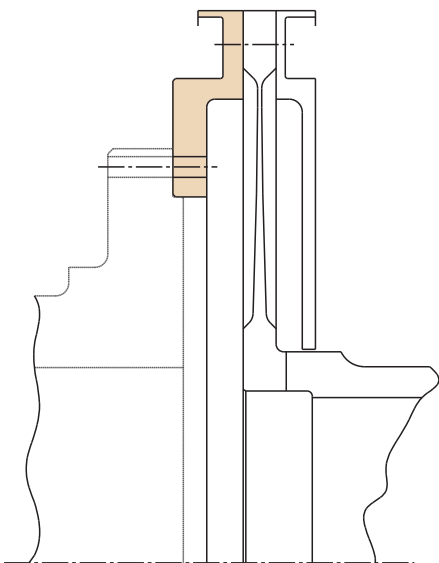

Integral Flange

Example 2

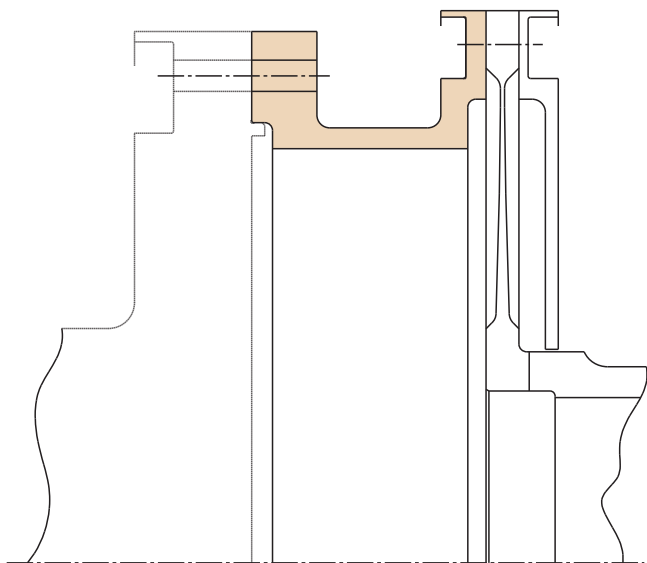

Special Features

Back-up Gear

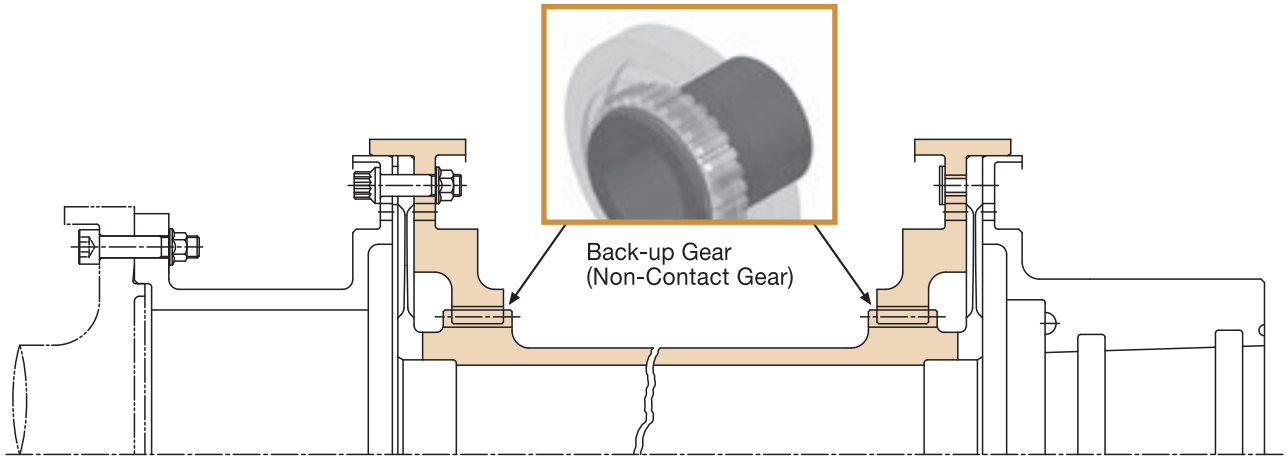

Spark Resistant

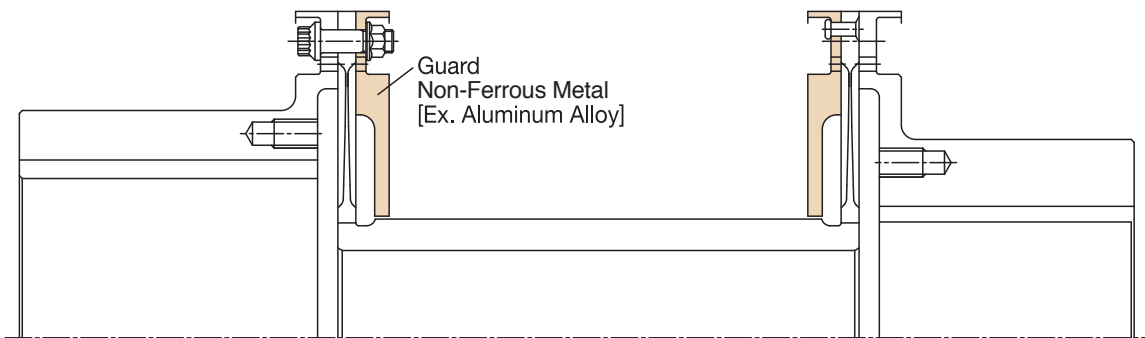

Electrically Insulated

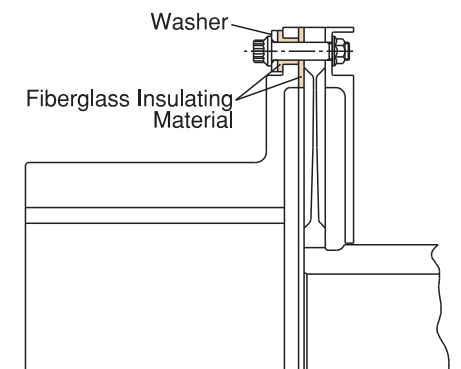

Shear Pin

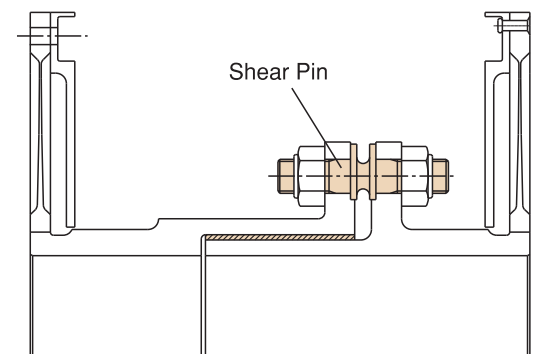

Special Features

Torque Monitoring System

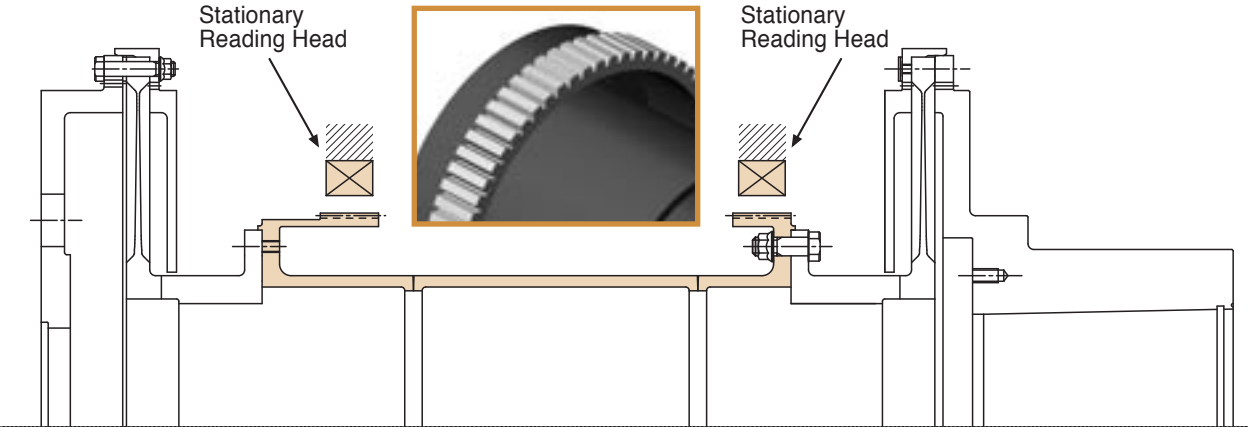
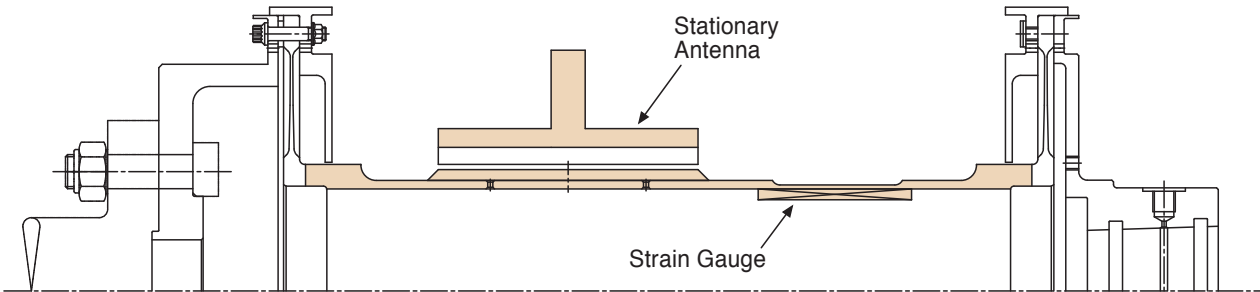

System Arrangement

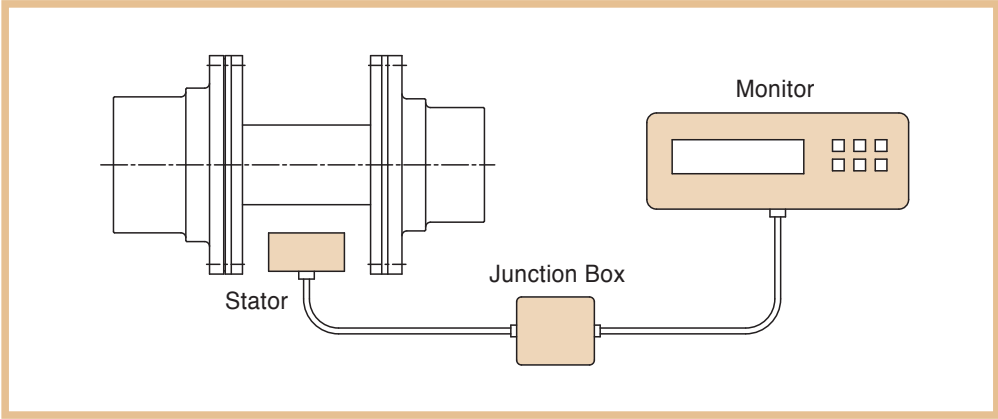

Test Equipment

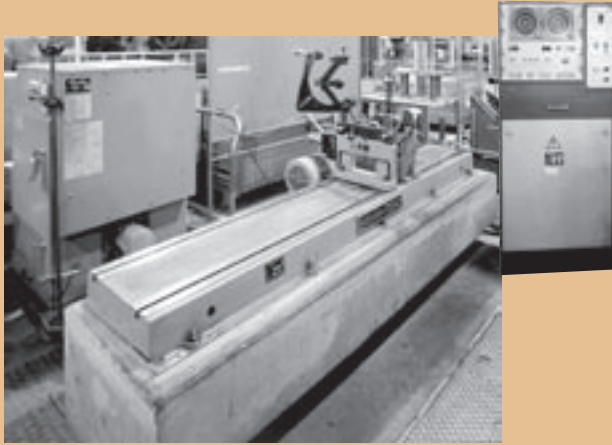

▲Balancer

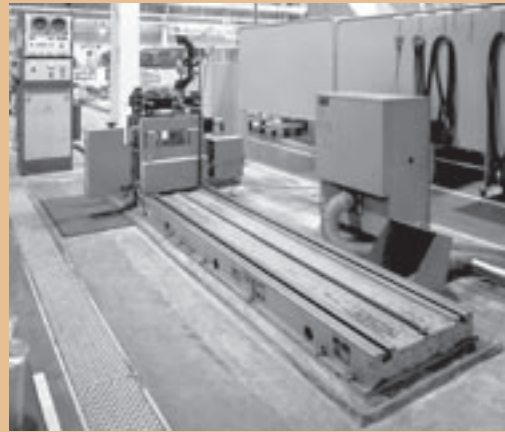

▲Balancer



▲Balancer



▲Balancer

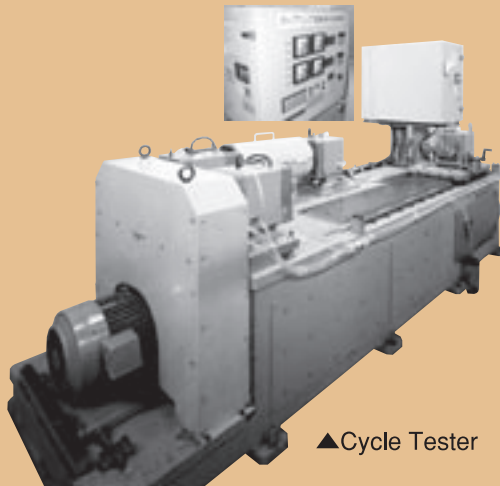

▲Cycle Tester



▲Twist Tester

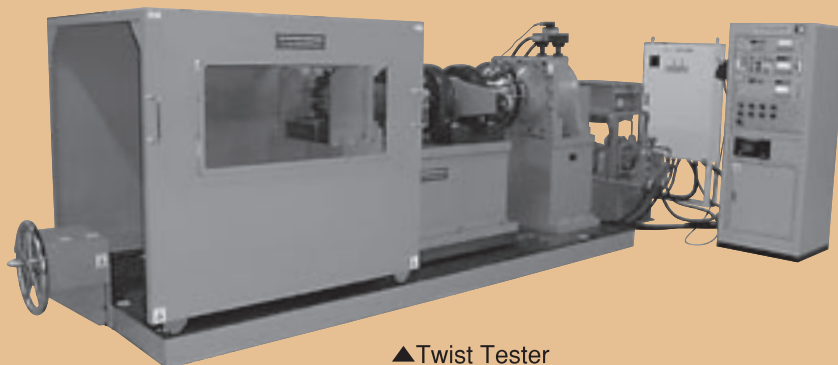

▲Twist Tester

Coupling Purchase Specification

For quick response, we would kindly ask you to fill this form and send to us by fax or e-mail.

Company Name		Contact Person	
Address			
Phone		E-mail	

Specification

Driver Machine	New Purchase <input type="checkbox"/> Yes
Driven Machine	<input type="checkbox"/> No ⇒ DWG No.: _____

Dynamic Balance

Required ⇒ Scope Flex Unit Only ⇒ Standard : _____
 Not Required Hub (Driver Side) (Ex. API610, API671, JIS G 1.0 ...)
 Hub (Driven Side)
 Assembly Balance Note : _____
 Assembly Check

Torque Data

	Normal	Maximum Transient	Continuous Cyclic	Trip
Power (kW)				/
Speed (rpm)				
Torque (Nm)				/

Applicable Standard

<input type="checkbox"/> API671	Edition	<input type="checkbox"/> ISO10441	Edition	Others:
<input type="checkbox"/> API610	Edition	<input type="checkbox"/> ISO14641	Edition	

Requirement

Mass	kg	Angular Deflection	rad
Moment of Inertia	kg-cm ²	Parallel Offset	mm
Torsional Stiffness	Nm/rad	Axial Deflection ^{※1}	mm
Max. O.D.	mm	Others	

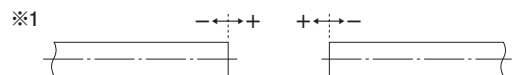

Note

Coupling Purchase Specification

Hub Dimensions

	Driver Side		Driven Side	
Inside Diameter (I.D.)	Straight	mm	Straight	mm
	Taper (LD)	mm	Taper (LD)	mm
Fit	<input type="checkbox"/> Keyed <input type="checkbox"/> Hydraulic		<input type="checkbox"/> Keyed <input type="checkbox"/> Hydraulic	
Key Dimension	<input type="checkbox"/> Single Key <input type="checkbox"/> Double Key		<input type="checkbox"/> Single Key <input type="checkbox"/> Double Key	
	Key Width	W mm	Key Width	W mm
	Key Height	H1 mm	Key Height	H1 mm
		H2 mm		H2 mm
		H3 mm		H3 mm
	Radius	R mm	Radius	R mm
	<input type="checkbox"/> Key is parallel to shaft		<input type="checkbox"/> Key is parallel to shaft	
<input type="checkbox"/> Key is parallel to taper		<input type="checkbox"/> Key is parallel to taper		

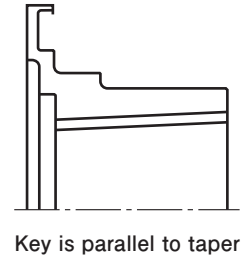
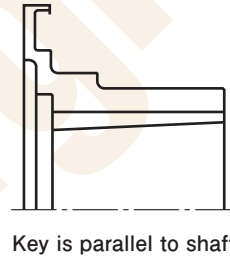
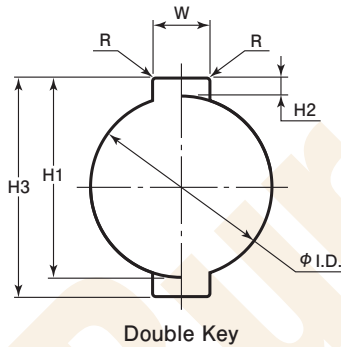
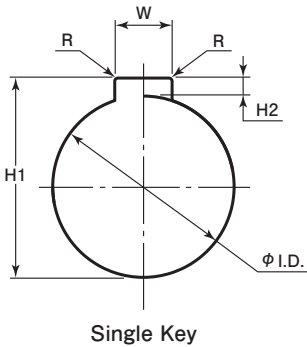

Shaft Dimensions

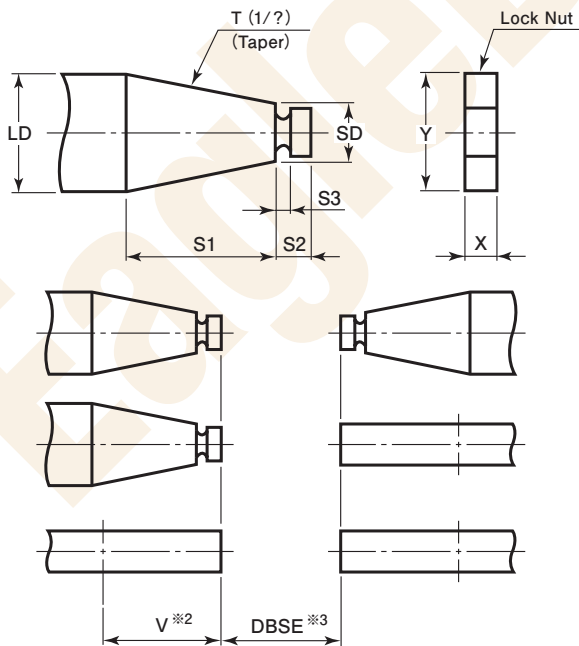

	Driver Side	Driven Side
LD	mm	mm
SD	mm	mm
S1	mm	mm
S2	mm	mm
S3	mm	mm
T (1/?)		
X	mm	mm
Y	mm	mm
V	mm	mm
DBSE		mm

※2: Effective Length
 ※3: Distance Between Shaft Ends

Your nearest EagleBurgmann representative

EagleBurgmann Network

■ Europe

Austria

EagleBurgmann Austria GmbH
Vogelweiderstrasse 44a
A-5020 Salzburg, Austria
Phone: +43-662-82 57 01
Fax: +43-662-82 57 03

Belgium

EagleBurgmann Belgium B.V.B.A.
Zagerijstraat 11
B-2960 Sint-Job-in't-Goor, Belgium
Phone: +32 3 63 39 944
Fax: +32 3 63 39 949

Czech Republic

EagleBurgmann Czech s.r.o.
Na Draháč 1364
CZ-156 00 Praha 5 - Zbraslav
Czech Republic
Phone: +420 257920505
Fax: +420 257920508

Denmark

EagleBurgmann KE A/S
Park Allé 34, DK-6600 Vejen, Denmark
Phone: +45-75 36 18 11
Fax: +45-75 36 15 32

France

EagleBurgmann France S.A.S.
Zone d'Activité les Perriers, 106/108 Route
de Cormeilles, BP 96, F-78505 Sartrouville
France
Phone: +33-1-30 86 50 20
Fax: +33-1-39 15 16 07

Germany

EagleBurgmann Germany GmbH & Co. KG
Äussere Sauerlancher Str. 6-10, D-82515
Wolfratshausen, Germany
Phone: +49-8171-23-1230
Fax: +49-8171-23-1214

Hungary

EagleBurgmann Hungaria Kft
Lejtő utca 6
H-1124 Budapest, Hungary
Phone: +36 1 814 81 60
Fax: +36 1 319 8125

Italy

EagleBurgmann Italia s.r.l.
Viale Martiri della Liberazione, 12 23875
Osnago (LC), Italy
Phone: +39-039-95 22 501
FAX: +39-039-928 94 20

EagleBurgmann BT S.p.A.

Via Meucci, 58
36057 Arcugnano (VI), Italy
Phone: +39-0444-28 8977
Fax: +39-0444-28 8971

Netherlands

EagleBurgmann Netherlands B.V.
Koningsschoot 9, NL-3905 PP
Veenendaal, Netherlands
Phone: +31-318-54 20 00
Fax: +31-318-54 15 35

Norway

EagleBurgmann Norway AS
P.O. Box 143, Industriveien 25 D, N-2021
Skedsmokorset, Norway
Phone: +47-64-83 75 50
Fax: +47-64-83 75 75

Poland

EagleBurgmann Poland Sp. z o.o.
Al. Jerozolimskie 200, PL-02-486 Warsaw
Poland
Phone: +48-22-535-16 00
Fax: +48-22-535-16 48

Russian Federation

EagleBurgmann OOO Moscow
Godovikova Str. 9, Building 3
129085 Moscow, Russian Federation
Phone: +7 495 721 2981
Fax: +7 495 721 2980

Spain

EagleBurgmann Ibérica S.A.
Avda. de Quitapesares, 40
E-28670 Villaviciosa de Odón - Madrid
Spain
Phone: +34 916166601
Fax: +34 916166681

Sweden

EagleBurgmann Sweden AB
Svärmaregatan 3
SE-603 61 Norrköping, Sweden
Phone: +46 11140005
Fax: +46 11140015

Switzerland

EagleBurgmann (Switzerland) AG
Hofstrasse 21
CH-8181 Hoeri
Switzerland
Phone: +41 448723930
Fax: +41 448723940

United Kingdom

EagleBurgmann Industries UK LP
3 Wilton Drive, Tournament Fields
Warwick, CV34 6RG, United Kingdom
Phone: +44-1926-41 76 00
Fax: +44-1926-41 76 17

■ Africa

South Africa

EagleBurgmann Seals South Africa (PTY) Ltd.
P.O. BOX 1210 Edenvale, 1610 Gauteng,
South Africa
Phone: +27 11 457 9000
Fax: +27 11 609 3008

■ Middle East

Saudi Arabia

EagleBurgmann Saudi Arabia Co. Ltd.
Near Saudi Lucy, Al Fahya Industrial Area,
Azizyah Road
P. O. Box: 77148, 31952 Al Khobar
Kingdom of Saudi Arabia
Phone: +966 13 8906111
Fax: +966 13 8906222

U.A.E.

EagleBurgmann Middle East, FZE
Jebel Ali Free Zone, Section RA08, Building CC06
P.O. Box. 61310, Jebel Ali Dubai
Phone: +971 48838841
Fax: +971 48838843

Turkey

EagleBurgmann Endüstriyel Sızdırmazlık
Sanayi Ve Ticaret Ltd.
Aydınlı-KOSB Mah.
Tuzla Kimya Sanayicileri Organize Sanayi
Bölgesi
Tuna Cad. No: 8, TR-34953 Tuzla / Istanbul
Turkey
Phone: +90 216 593 0293
Fax: +90 216 593 0298

Head Office

Japan

EagleBurgmann Japan Co., Ltd.
Shiba Park Bldg. B-14F, 2-4-1, Shibakoen,
Minato-ku, Tokyo, 105-8587, Japan
Phone: +81-3-3438-1337
Fax: +81-3-3438-2370
<http://www.eagleburgmann.com>

Head Office

Germany

EagleBurgmann Germany GmbH & Co. KG
Äussere Sauerlancher Str. 6-10, D-82515
Wolfratshausen, Germany
Phone: +49-8171-23-1230
Fax: +49-8171-23-1214

Asia & Oceania

Australia

EagleBurgmann Australasia Pty Ltd.
16 Stennett Road, Ingleburn, NSW 2565
Australia
Phone: +61-2-96 05 64 44
Fax: +61-2-98 29 69 58

China

Burgmann Shanghai Co., Ltd.
No. 127-8 WenJing road MinHang
200245 Shanghai, China
Phone: +86-21-6462-0550
Fax: +86-21-6430-8364

Burgmann Dalian Ltd.
No. 86 Liaohe East Road, DD Port
116620 Dalian, China
Phone: +86 411 8758 1000
Fax: +86 411 8758 1397

EagleBurgmann Technology (Shanghai) Co. Ltd.
Room 606, Block 6, No. 3611 Zhangyang Rd,
Pudong 200136 Shanghai
Peoples Republic of China
Phone: +86 (0) 21 5077 6320
Fax: +86 (0) 21 5077 6317

India

EagleBurgmann India Pvt Ltd
Plot No.64, Survey No 91/B Ramtekadi
Industrial Estate, Hadapsar, Pune India 411013
Phone: +91-20-2681 2901
Fax: +91-20-2681 2915

EagleBurgmann Mascot India Private Ltd.
INDIPLEX-III, Plot No.16-A, Gandhi Industrial
Estate, Behind Kashmir Police Station,
Kashimira, Mira Road East, Thane 401104,
India
Phone: +91-22-2845 4519

EagleBurgmann KE Pvt. Ltd.
Survey No. 109/2A-1B, Old GNT Road,
Karanodai, Sholavaram, Chennai
600067 Chennai India
Phone: +91 44 3088 2700
Fax: +91 44 3088 2720

Americas

Argentina

EagleBurgmann Argentina
Catalina M. de Boyle 3117 (calle 28)
B1650AVI San Martin,
Provincia de Buenos Aires / Argentina
Phone: +54 (11) 4754 6373
Fax: +54 (11) 4754 6373

Brazil

EagleBurgmann do Brasil Vedacoes Industriais
Ltda.
Av. Santa Izabel,
1721 Barao Geraldo Caixa Postal 6560
CEP-13084-643 Campinas - Sao Paulo, Brazil
Phone: +55-19-37 49 97 40
Fax: +55-19-37 49 97 42

Indonesia

P.T. EagleBurgmann Indonesia
East Jakarta Industrial Park (EJIP) Plot
7G-4. South Cikarang, Bekasi 17550, West
Java, Indonesia
Phone: +62-21-897-5728
Fax: +62-21-897-5729

Japan

EagleBurgmann Japan Co., Ltd.
Shiba Park Bldg. B-14F, 2-4-1, Shibakoen,
Minato-ku, Tokyo, 105-8587, Japan
Phone: +81-3-3438-1337
Fax: +81-3-3438-2370

Korea

EagleBurgmann Korea Co.,Ltd.
376-4, Gajang-dong, Osan-si,
Gyeonggi-do, 447-210, Korea
Phone: +82 31 375 4095
Fax: +82 31 375 4092

Malaysia

EagleBurgmann (Malaysia) Sdn. Bhd.
No. 25 & 27, Jalan SS15/23, Taman
Perindustrian Tiong Nam, Seksyen 15,
40200, Shah Alam, Selangor, Malaysia.
Phone: +60-3-5524-6421
Fax: +60-3-5524-6428

New Zealand

EagleBurgmann Australasia Pty. Ltd.
47 William Pickering Drive, Rosedale
0632 Auckland
New Zealand
Phone : +64 9448 5001
Fax : +64 9415 0599

Philippines

EagleBurgmann Philippines Inc.
No. 9769 National Road, Maduya,
Carmona, Cavite
4116 Philippines
Phone: +63-2-666-2770
Fax: +63-46-430-1428

Canada

EagleBurgmann Canada Inc.
8699 Escarpment Way, Units #9 & #10
L9T 0J5 Milton, Ontario Canada
Phone: +1-905-693-8782
Fax: +1-905-693-0535

Mexico

EagleBurgmann Mexico S.A. de C.V.
Calzada de Guadalupe Num. 350-6, Col.
El Cerrito C.P. 54720, Cuautitlán Izcalli,
Estado de México, Mexico City
Phone: +52-55-5872-2513
Fax: +52-55-5872-6493

Singapore

EagleBurgmann Singapore Pte. Ltd.
15 Kwong Min Road, Singapore 628718
Phone: +65-6481-3439
Fax: +65-6481-3934

EBI Asia Pacific Pte. Ltd.
Regional Office
1 International Business Park, #03-01A The
Synergy Singapore 609917
Phone: +65-6565-6623
Fax: +65-6565-9663

EagleBurgmann KE Pte. Ltd.
3 Tuas Drive 1, 638670 Singapore,
Singapore
Phone: +65 6261 8581
Fax: +65 6261 8589

Taiwan

EagleBurgmann Taiwan Co., Ltd.
No. 18, Beiling 2 road, Luzhu District,
Kaohsiung 821, Taiwan
Phone: +886-7-695-5689
Fax: +886-7-695-5200

Thailand

EagleBurgmann (Thailand) Co.,Ltd. / Rayong
13/2 Klongnamhu Rd., (Sukhumvit 54Rd.)
T.Nernpla, A Muang 21150 Rayong,
Thailand
Phone: +66 38 694 422
Fax: +66 38 694 419

Vietnam

EagleBurgmann Vietnam Co, Ltd.
343 Pham Ngu Lao Street 6th Floor Suite
6B2 International Plaza Pham Ngu Lao
Ward • District 1 Ho Chi Minh City Vietnam
Phone: +84-8-6291-5648
Fax: +84-8-6291-5649

USA

EagleBurgmann Industries LP
10035 Brookriver Dr., Houston,
Texas 77040, USA
Phone: +1-713-939 9515
Fax: +1-713-939 9109

Venezuela

EagleBurgmann Venezuela, C.A.
Final Calle Milán con Calle Miranda,
Edificio SBR piso 01,
Los Ruices Sur (Detrás de Plumrose)
1071 Caracas - Edo. Miranda, Venezuela
Phone: +58 2122561910
Fax: +58 2122580577

Argentina · Australia · Austria · Belarus · Belgium · Bulgaria · Brazil · Canada · Chile · China · Colombia · Cyprus · Czech Republic · Denmark · Ecuador · Egypt · Estonia
Finland · France · Germany · Great Britain · Greece · Hungary · India · Indonesia · Irak · Iran · Israel · Italy · Japan · Jordan · Kazakhstan · Korea · Kuwait · Latvia · Libya
Lithuania · Malaysia · Mauritius · Mexico · Morocco · Myanmar · Netherlands · New Zealand · Nigeria · Norway · Oman · Pakistan · Paraguay · Peru · Philippines · Poland
Qatar · Romania · Russia · Saudi Arabia · Singapore · Slovenia · Slovakian Republic · South Africa · Spain · Sweden · Switzerland · Syria · Taiwan · Thailand · Trinidad and
Tobago · Tunisia · Turkey · Turkmenistan · Ukraine · United Arab Emirates · Uruguay · USA · Uzbekistan · Venezuela · Vietnam · www.eagleburgmann.com/world



EagleBurgmann is one of the leading international companies for industrial sealing technology. Our products are used everywhere that safety and reliability are important: In the oil and gas industries, petroleum refining, chemicals, energy, food, paper, water, marine applications, aerospace and mining. Every day, more than 5000 employees contribute their ideas, solutions and commitment to ensuring that customers all over the world can rely on our seals. Our modular seal service, TotalSealCare™, underlines our commitment to customer orientation and our provision of tailor-made services for every application.

EagleBurgmann Japan Co., Ltd.

Head Office

Shiba Park Bldg. B-14F, 2-4-1, Shibakoen, Minato-ku, Tokyo,
105-8587, Japan
Phone: +81-3-3438-1337 Fax: +81-3-3438-2370

EagleBurgmann®