

# Magnetic Fluid Seal



# Design specifications tailored to client requirements

The NOK group produces the full range of vacuum seal components including O-rings, bellows, bearing lubrication grease and magnetic fluids (see diagram).

This enables us to tailor our products to the precise design requirements of individual clients.

- Typical configurations
- Multi-axial (two or three shafts)
  - Reciprocating (bellows seal)
  - Pressurized

## Typical twin-axial reciprocating vacuum seal

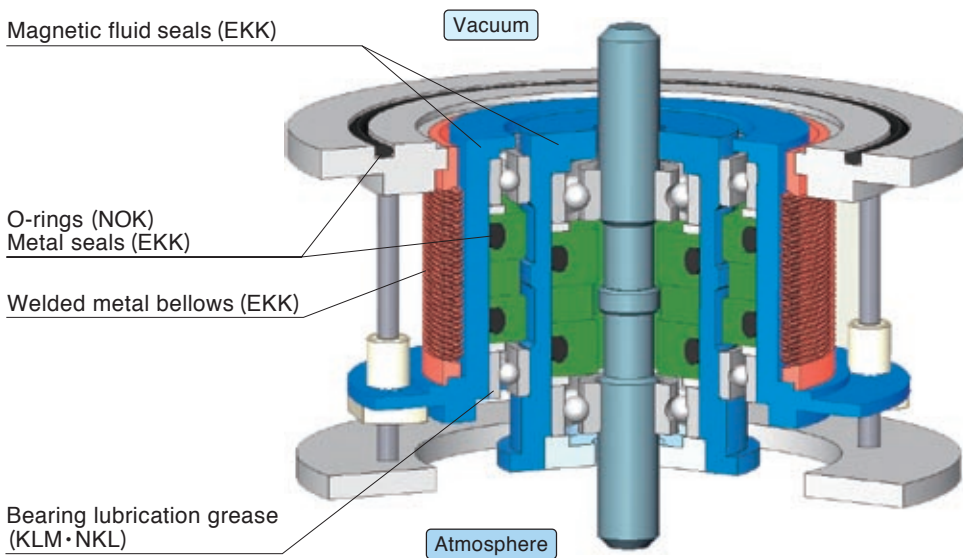

EKK : EAGLE INDUSTRY CO.,LTD  
NOK : NOK CORPORATION  
KLM : KLÜBER LUBRICATION MÜNCHEN SE & CO.KG  
NKL : NOK KLÜBER CO.,LTD



# Uses of the magnetic fluid seal

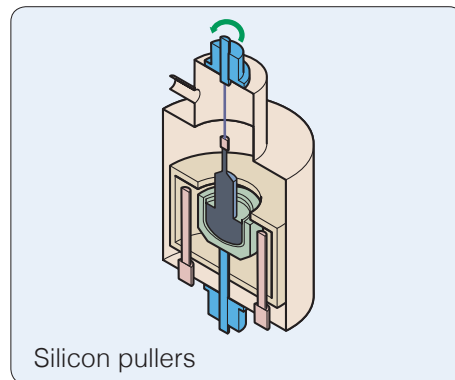
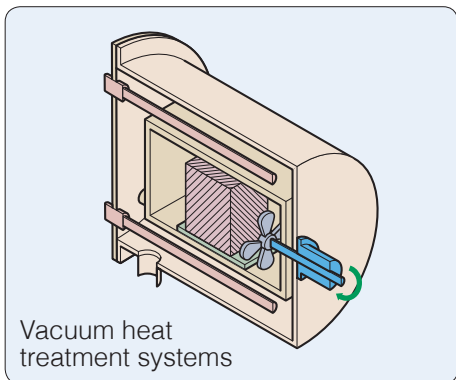
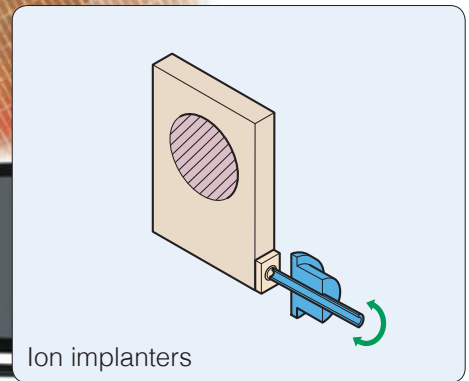
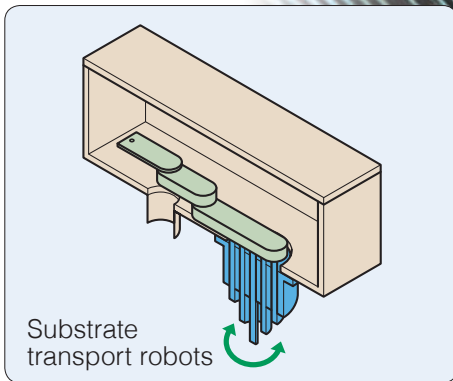
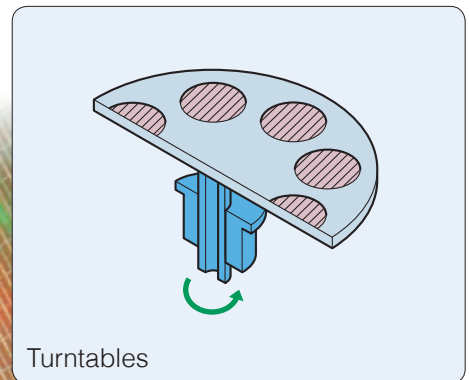
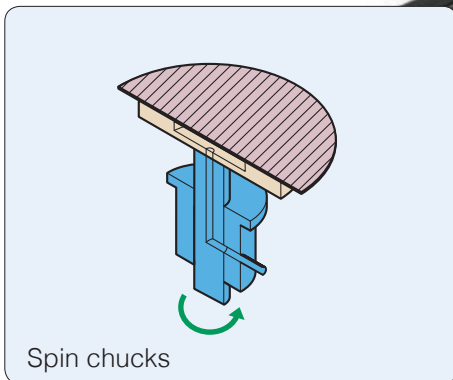
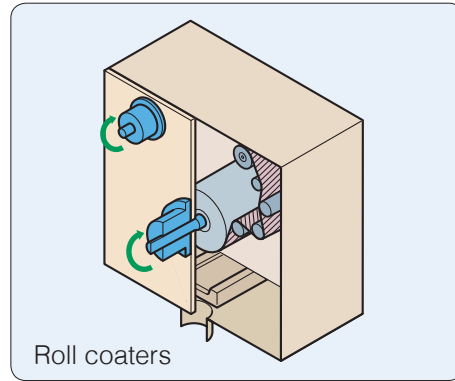
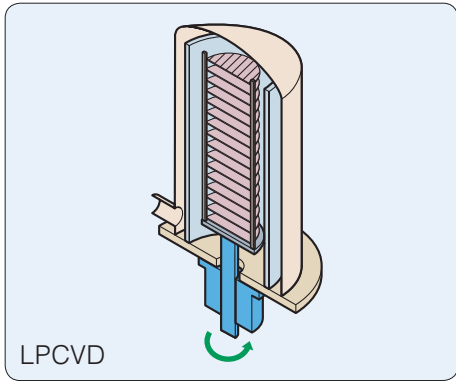

Magnetic fluid seals from Eagle Industry are employed in a wide range of industrial applications including manufacturing (typically semiconductors, LCD panels, solar panels and LED devices) as well as industrial machinery, analyzers and clean robots. Our high-performance and high-reliability seals have been adopted throughout the world.



# What is magnetic fluid?

Essentially, magnetic fluid is a liquid that is attracted to magnets—in other words, a magnetized liquid.

Magnetic fluid consists of three components:

(1) magnetic particles, (2) surfactant and (3) a base liquid.

The performance of a magnetic fluid seal is largely dependent on the properties of the magnetic fluid. Without surfactant, the very small magnetite ( $\text{Fe}_3\text{O}_4$ ) particles (approximately  $0.01\mu\text{m}$ ) tend to separate and settle and do not remain evenly mixed with the base liquid. The surfactant envelops the magnetic particles and causes them to oppose one another within the base liquid. This prevents settlement and maintains a uniform distribution of particles (see diagram below).

Eagle Industry boasts an extensive understanding of the many parameters of magnetic fluids including particle size, surfactant structure, molecular weight and particle absorption, base liquid purity, surfactant compatibility and dispersion characteristics. These parameters are carefully tailored to produce optimized magnetic fluids for different applications.

***Base liquids are designed and manufactured within the NOK group.***

One of the major strengths of Eagle Industry magnetic fluids is that all of the constituent components are designed and manufactured within the NOK group. Our products offers superior high-temperature durability, corrosion resistance, plasma resistance and very low-temperature outgassing performance compared to competitors' products.

Magnetic fluid seals from Eagle Industry utilize magnetic fluids that have passed a stringent final quality testing process prior to delivery.

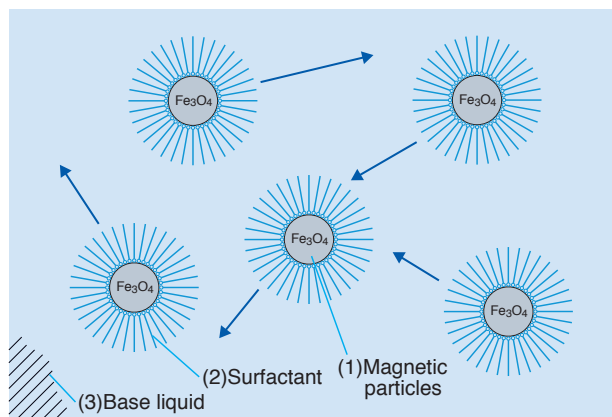

## Spiking

When a magnet is brought close to magnetic fluid, the magnetic fluid attempts to orient itself with the magnetic force lines. This acts in opposition to interfacial tension, resulting in the phenomenon known as spiking (see photograph).

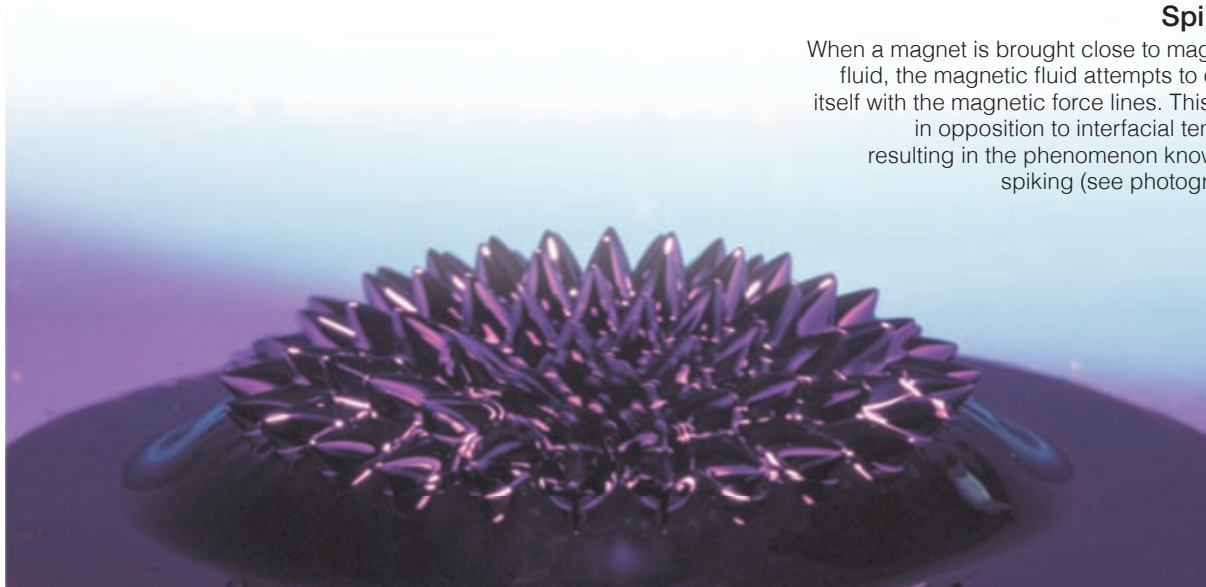

## Magnetic fluid selection table

Product code	3019	3512	3551	3576
Base liquids	Alkyl naphthalene	Perfluoropolyether		
Saturation magnetization (at 25°C) mT	32	35	35	35
Viscosity (at 25°C) mPa·s	220	3500	<10000	<10000
Vapor pressure (at 20°C) Pa	3.0E-7	6.0E-8	4.0E-13	7.5E-15
Application	General purpose	For activated gases	Ultra high vacuum environments/Heat resistant	
Common uses	Dust seals	Dust seals/ Vacuum seals	Vacuum seals	Vacuum seals

\* Magnetic fluid is not sold as a stand-alone product.

High performance

## Vapor Pressure Chart of Magnetic Fluid

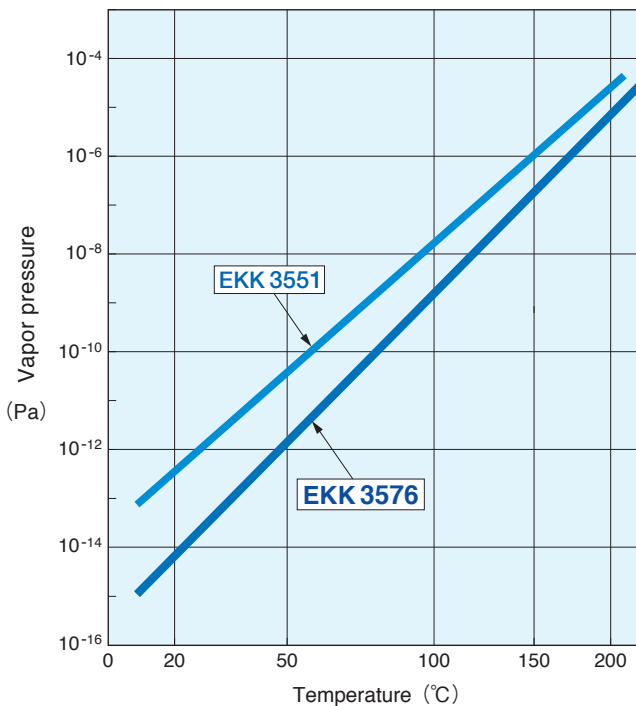

### Features of Eagle Industry magnetic fluids

- Excellent heat resistance—no need to provide cooling equipment/structures\*  
This also helps to minimize by-products associated with localized cooling of CVD equipment.
- Allows extremely high vacuum environments to be generated via direct exhaust (i.e. without differential pumping)
- Low outgassing
- Excellent corrosion and plasma resistance

\* Eagle Industry will be happy to recommend the best process setup and magnetic fluid for your particular operating environment and objectives. To apply, simply fill in the Magnetic Fluid Seal Design Request attached to this catalog (general specifications are acceptable) and present it to your nearest dealer or distributor.

# What is a magnetic fluid seal?

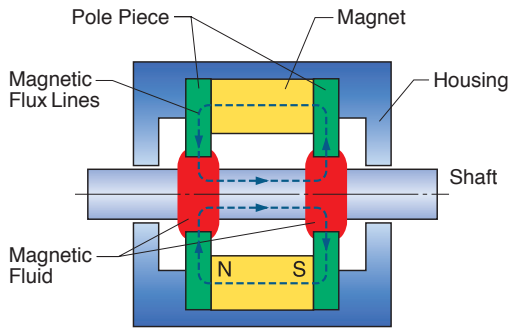

The term "magnetic fluid seal" is a generic term used to describe all seals that employ magnetic fluids.

A magnetic fluid seal is filled with magnetic fluid that is oriented with the magnetic force lines created by the shaft, magnet and pole pieces. The sealing action is provided by a sealing skin called the liquid O ring that is formed by the magnetic fluid.

Magnetic fluid seals have superior longevity to solid seals as well as lower torque due to the absence of abrasion. However they are not suitable for use with liquids such as water.

# About magnetic fluid vacuum seals

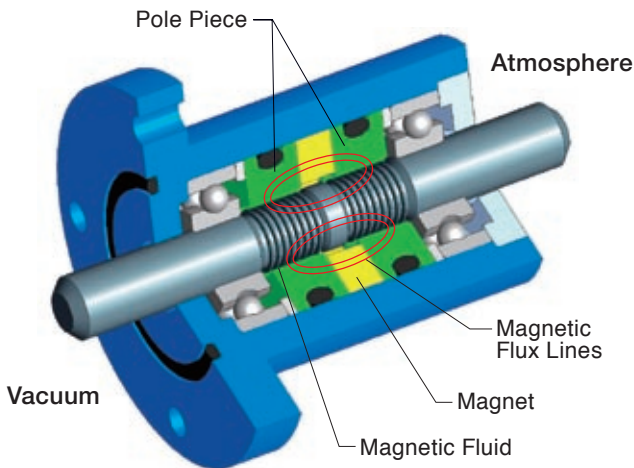

A magnetic fluid vacuum seal is a special type of magnetic fluid seal used to keep a vacuum.

Magnetic fluid vacuum seals are used for delivering rotational power to vacuum chambers, typically in electronic manufacturing systems (such as semiconductors) and analysis equipment.

Since pressure resistance of one atmosphere (101.3 kPa) cannot be achieved via a single stage, a multi-stage design is used. Where the pressure differential exceeds the resistance of a stage, gas passes through the magnetic fluid, which then repairs itself. As this process occurs at successive stages, the pressure is apportioned between the stages, creating an equilibrium that maintains the seal. Note that if vacuum pumping is performed too quickly, the self-repair function cannot keep up and the magnetic fluid bursts.

Some seals feature multiple shafts in a coaxial or parallel configuration.

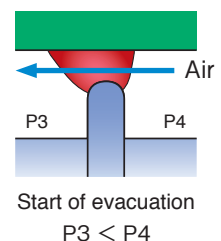
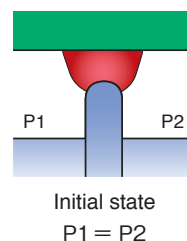
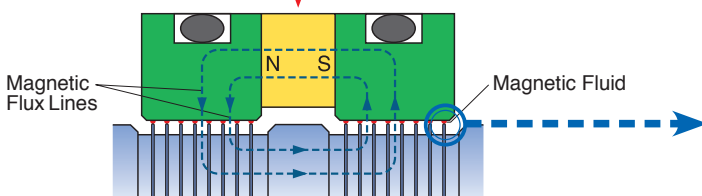
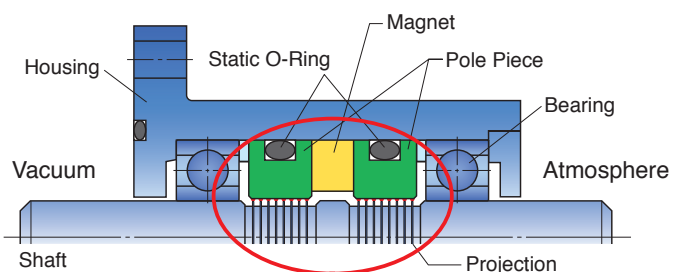

# About magnetic fluid seals

Magnetic fluid is a colloidal liquid consisting of nano-sized magnetic particles distributed through a liquid body. As the name suggests, magnetic fluid is attracted to magnetic bodies.

Magnetic fluid was originally developed in 1965 by S. S. Papell from NASA (National Aeronautics and Space Administration) as a rocket fuel propulsion technology for weightless environments(1). Subsequent modifications and enhancements have seen magnetic fluids adopted in a wide range of applications from the everyday to the cutting-edge.

A magnetic fluid seal is a type of seal that utilizes magnetic fluid.

Dust seals and vacuum (or hydraulic) seals generate minimal levels of dust, friction and contamination and provide excellent heat and plasma resistance. As such, they are extensively used in clean production environments, typically for manufacturing semiconductors, LCD panels, solar panels and LED components.

## Timeline of magnetism research and magnetic fluid seals at Eagle Industry

- 1984** | NOK Corporation launches research on in-house production of magnetic fluid products.
- 1988** | Commences production and distribution of dust seals.
- 1990** | Commences production and distribution of vacuum seals.
- 1996** | Develops magnetic fluid 3551 featuring low vapor pressure and high heat resistance. Announces vacuum seals rated to E-8Pa. (see page 4)
- 1999** | Announces magnetic fluid 3576, an improved version of 3551. Commences production and distribution of vacuum seals for extremely high vacuum environments (E-13Pa).
- 2002** | NOK Corporation transfers production operations to group company Eagle Industry Co., Ltd.. Eagle Industry commences production and distribution of magnetic fluid 3576.

# General purpose through to extremely high vacuum specifications

## Table of dimensions (for reference)

### Features

- Pressure (vacuum): **E-6Pa** (at R.T.)
- Allowable He leakage:  
less than **9.9E-11Pa·m<sup>3</sup>/s**
- Operating temperature:  
from room temperature to **160°C**
- Usage environment: reactive gases/inert gases



### Table of dimensions (for reference)

#### ISF type

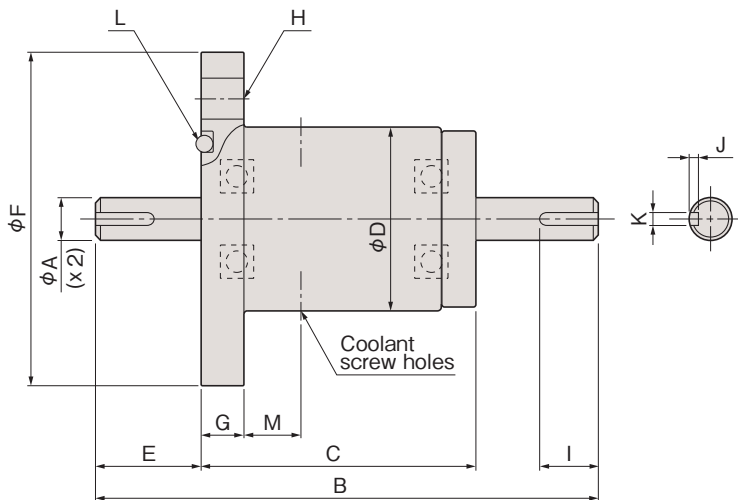

Symbol	ISF010	ISF020	ISF030	ISF040
A	10h7	20h7	30h7	40h7
B	115	139	167	194
C	65	70	77	84
D	44	58	73	84
E	25	35	45	55
F	80	105	120	145
G	10	10	10	12
H	4-φ10 (PCD60)	4-φ10 (PCD85)	4-φ10 (PCD100)	6-φ10 (PCD120)
I	14	25	32	45
J	1.8	3.5	4	5
K	3	6	8	12
L	V34	V55	V70	V85
M	14	16	21	23

\* W suffix on model number denotes water-cooled type.  
Example: **ISF010W**

\* Dimensions subject to change without notice.

#### IHF type

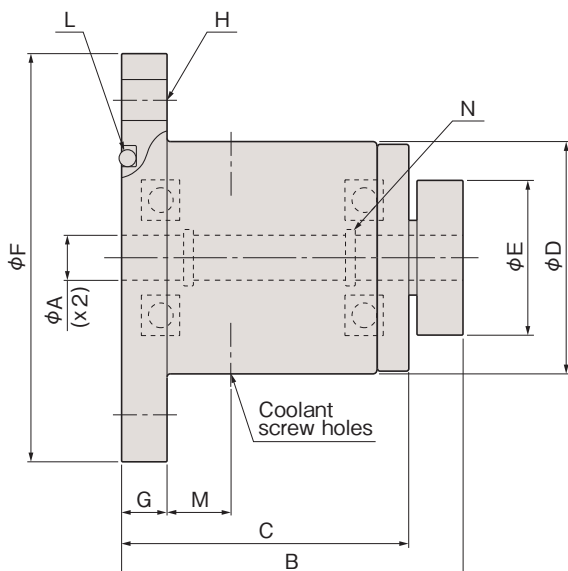

Symbol	IHF010	IHF020	IHF030	IHF040	IHF050	IHF075
A	10H7	20H7	30H7	40H7	50H7	75H7
B	75	80	92	94	96	113
C	63	68	80	80	82	96
D	51	63	78	88	103	143
E	34	44	54	69	79	118
F	90	105	120	145	160	210
G	10	10	10	10	12	12
H	4-φ10 (PCD70)	4-φ10 (PCD85)	4-φ10 (PCD100)	6-φ10 (PCD120)	6-φ12 (PCD135)	8-φ12 (PCD185)
L	V40	V55	V70	V85	V100	V150
M	14	15.5	23	23	21	28
N	S10	S20	S30	S40	S50	S75

\* W suffix on model number denotes water-cooled type.  
Example: **IHF010W**

\* Dimensions subject to change without notice.



# Extremely high vacuum specifications

## Table of dimensions (for reference)

### Features

- Pressure (vacuum): **E-9Pa** (at R.T.)
- Allowable He leakage:  
less than **9.9E-12Pa·m<sup>3</sup>/s**
- Operating temperature:  
from room temperature to **220°C**
- Usage environment: reactive gases/inert gases



### Table of dimensions (for reference)

#### ASF type

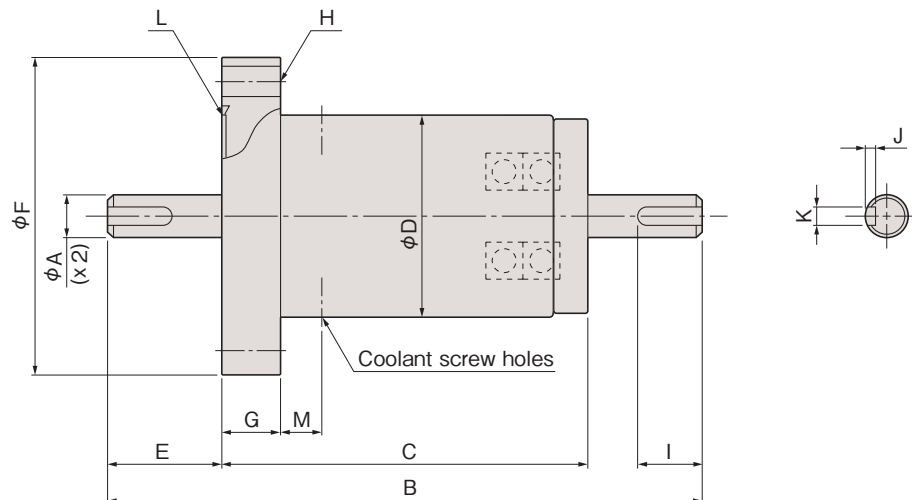

Symbol	ASF010	ASF020	ASF030	ASF040	ASF050
A	10h7	20h7	30h7	40h7	50h7
B	129	164	191	217	241
C	79	94	101	107	112
D	44	63	78	91	106
E	25	35	45	55	65
F	70	114	152	152	152
G	13	18	21	21	21
H	6-φ6.6 (PCD58.7)	8-φ8.4 (PCD92.1)	16-φ8.4 (PCD130.2)	16-φ8.4 (PCD130.2)	16-φ8.4 (PCD130.2)
I	14	25	32	45	55
J	2.5	3.5	4	5	6
K	4	6	8	12	16
L	ICF70	ICF114	ICF152	ICF152	ICF152
M	9	9	9	9	9

\* W suffix on model number denotes water-cooled type. Example: **ASF010W**

\* Dimensions subject to change without notice.

Vacuum seals can be designed to other configuration or specifications as required.  
Contact your local dealer or distributor for more information.

# Dust seal

Dust seals are used to shut out dirt and contaminants from the atmosphere, as well as contaminants generated by bearing grease. A dust seal consists of a magnet, two pole pieces and a shaft, which form a magnetic circuit that holds magnetic fluid in the gaps between the shaft and the pole pieces.



## Features

- Pressure differential: **1kPa** (10kPa)
- Operating temperature: from room temperature to **160°C** (220°C)
- Circumferential velocity: **~3m/s** (~6m/s)
- Usage environment: reactive gases/inert gases

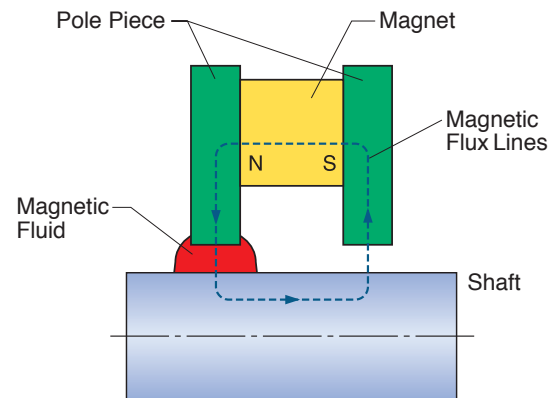

## Table of dimensions (for reference)

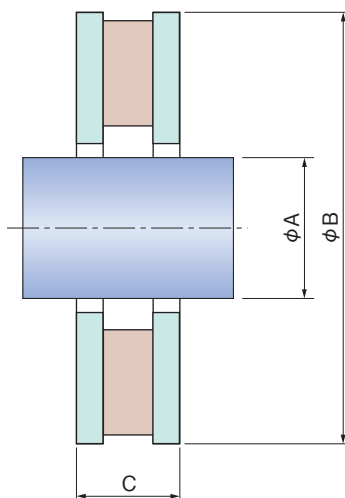

Shaft diameter $\phi A$ (mm)	Dust seal outer diameter $\phi B$ (mm)	Seal thickness C (mm)
10	20	4
20	30	4
30	40	4
40	50	5
50	60	5
60	70	5
70	80	5
80	90	5
90	100	5
100	120	6
110	130	6
120	140	6
130	150	6
140	160	6
150	170	6
160	180	6
170	190	6
180	200	6

\* Dimensions subject to change without notice.

## Use and handling of dust seals

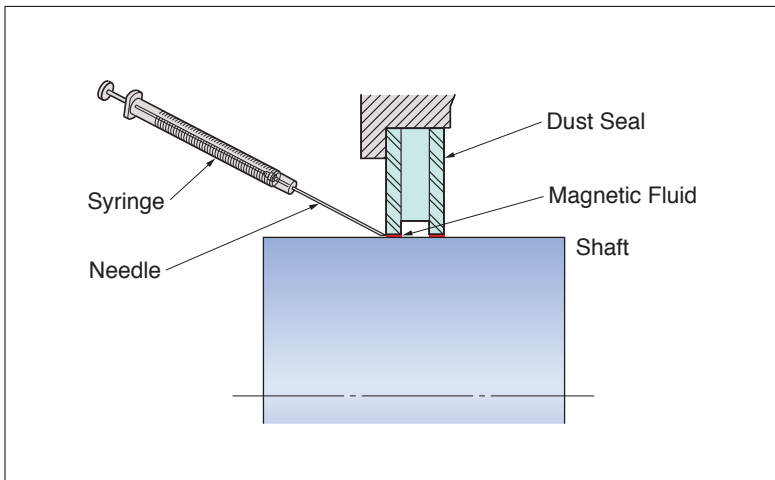

1. Dust seals and magnetic fluids should be stored in a cool location with low humidity and not in direct sunlight.
2. Do not mix magnetic fluid with other liquids.
3. Take care to avoid oil, grease and magnetic particle spills during use.
4. Use a suitable solvent to remove any grease or oil on the shaft surface.
5. Attach dust seals to housing using O-rings or adhesive to ensure a secure fit and a good seal.
6. Extract magnetic fluid from the container using the magnetic fluid syringe (optional).  
Take care to prevent air from entering the syringe.  
Air can affect measurement accuracy, which in turn can compromise the performance of the dust seal.  
If the magnetic fluid does not draw easily into the syringe, try warming the container first.
7. Apply magnetic fluid to the gaps between the shaft and the dust seal (or pole pieces).  
The correct quantities are indicated on the delivery drawings.
8. Use a suitable solvent to clean the syringe.

### [Option] Magnetic fluid syringe

The magnetic fluid syringe (optional extra) provides a clean, easy, accurate and efficient means of applying the magnetic fluid.



- Quantity: **500 $\mu$ l**
- Scale increments: **5 $\mu$ l**
- Needle (outer x inner diameter):  
 **$\varnothing$ 0.71x $\varnothing$ 0.41mm**
- Needle length: **51mm**

# Comparison Properties

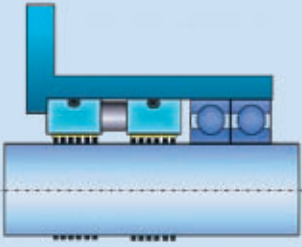
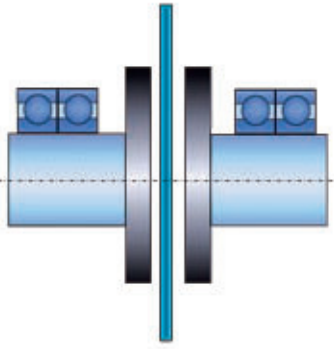
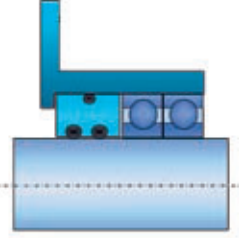
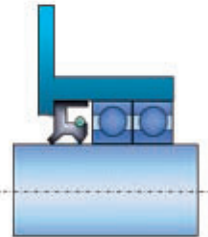
	Vacuum Level	Temperature (degree C) *No Cooling	Rotation speed Level	Torque transmission	Particle generation Rate (size more than 0.1 $\mu$ m)	Longevity	necessity of bearing support in vacuum chamber	Basic Structure
<b>Magnetic Fluid Seal</b>	Ultra high Vacuum (depends on magnetic fluid spec.)	up to 200°C	High	High (depends on Shaft strength)	Very Low	Very Long (depends on Bearing spec.)	—	
<b>Magnet Coupling</b>	High Vacuum (depends on Bearing spec.)	up to 850°C (depends on Bearing spec.)	Low	Low (Lost motion)	High (depends on Bearing spec.)	Long	Necessary	
<b>Oring Seal</b>	High Vacuum	up to 50°C	Low	High (depends on Shaft strength)	High (depends on Bearing spec.)	Short (depends on Bearing spec.)	—	
<b>Oil Seal</b>	High Vacuum	up to 50°C	Low	High (depends on Shaft strength)	High	Short	—	



# Usage and handling tips for magnetic fluid seals

## Usage and handling tips

1. Solvents or other fluids (such as acetone, alcohol, water and oils) or contaminants (such as solids and dust particles) inside a magnetic fluid seal can impact on performance. Take care to protect the seals from contamination. To clean the exterior of the seal, use a clean room wiper impregnated with a small quantity of ethyl alcohol. Note that too much ethyl alcohol on the wiper can cause drips, which could contaminate the seal and affect performance.
2. Leak testing should be performed using an He leak tester. Never use alcohol or solvents for leak tests. Solvents can contaminate the seal and affect performance.
3. Do not exceed the rated pressure (98 kPa for vacuum seals, or for pressurized seals, the maximum pressure stated on the delivery specifications or delivery drawings).
4. Magnetic fluid seals designed for inert gases should not be used with reactive gases. Reactive gases may affect performance and/or cause damage to structural components. Similarly, seals designed for use with reactive gases should only be used with the gases listed on the delivery specifications or delivery drawings. Non-listed gases may have an adverse effect on magnetic fluid and sealing performance.
5. Magnetic fluid seals must not be subjected to shock, such as being dropped or struck with a hammer, since sudden shock can cause damage to the internal bearings and structural components. If a seal is dropped, check carefully for signs of damage. A damaged seal should be replaced immediately. Remember that internal damage and deformation may not be externally visible.
6. When attaching a seal to equipment, center the seal first and use a coupling mechanism to connect it. When a seal is poorly centered, load imbalance may affect performance.
7. Water-cooled seals should be cooled using 1 - 3 liters per minute of ordinary mains water or equivalent coolant at normal temperature, taking care to avoid condensation. Condensation on the seal can affect performance and prevent normal rotation.
8. Keep seals away from magnets and magnetized devices such as speakers, since magnetism can affect sealing performance.
9. When using a vacuum seal for the first time, or when generating a vacuum after a long period of non-use, there may be a slight initial increase in pressure. Also, starting torque and loss torque tends to increase with the length of time that the seal is unused or in storage. These phenomena are associated with partial pressure balance and segmentation of magnetic fluid. For best results, the seal should be acclimatized with at least 20 rotations prior to generating a vacuum.
10. Where the chamber of a reactive gas vacuum seal is released to the environment, a cycle purge with N<sub>2</sub> gas is recommended in order to improve the consistency of sealing performance.
11. Seals should not be stored in locations that are humid, dusty, or subject to extremes of temperature. Ideally, seals should be kept in a clean room or other environment with temperature and humidity control. Do not open the vacuum packaging until ready to install the seal.

## Operating instructions

1. Do not touch the product while in operation.
2. Where a vacuum seal is suspected of causing abnormal pressure, stop the equipment and perform an He leak test. If the vacuum seal is found to be faulty, remove and replace immediately.
3. In the event of bad rotation, stop the equipment and turn the shaft by hand. If the rotation is found to be faulty, replace the seal.
4. If the seal is dropped or otherwise subjected to a strong external force, stop the device immediately and perform a leak test. Also turn the shaft by hand. If rotation is found to be faulty, replace the seal.

- Do not modify or disassemble magnetic fluid seals.
- In the event of a fault or defect, do not attempt to disassemble the seal. Contact Eagle Industry directly for advice.
- Any attempt to modify or disassemble a seal will void the warranty.

# Design Information Form for EKK Magnetic Fluid Seals

Date:

Your Name	
Title	
Company	
Address	
Phone	FAX
Email Address	

Equipment	( )	Number of pieces per an equipment	( )
SOP	From ( ) year ( ) month ( ) pieces per	<input type="checkbox"/> a month	• <input type="checkbox"/> a lot
Seal for	<input type="checkbox"/> Vacuum	<input type="checkbox"/> Pressure	<input type="checkbox"/> Dust (What kind of dust? )
Temperature range of seal device	( ~ ) °C	Usual	( ) °C
Gas	(What kind of Gases? )	<input type="checkbox"/> Inert gas	• <input type="checkbox"/> Active gas
Mouting direction	<input type="checkbox"/> Vertical (Vacuum side <input type="checkbox"/> up side • <input type="checkbox"/> down side )	•	<input type="checkbox"/> Horizontal
Rotation	Number of axis	<input type="checkbox"/> One • <input type="checkbox"/> Two • <input type="checkbox"/> Three • <input type="checkbox"/> More ( )	
	Motion	<input type="checkbox"/> Rotation • <input type="checkbox"/> Angular Deflection (Angle: )	
	Rotation speed	( , , )	<input type="checkbox"/> rpm • <input type="checkbox"/> Hz
	Start time	( ) rpm/sec	
Reciprocation	Stroke	( ) mm	
	Motion speed	( ) /	<input type="checkbox"/> min • <input type="checkbox"/> Hr
	Life	( ) cycles	
Pressure	Ultimate pressure ( )	<input type="checkbox"/> Pa • <input type="checkbox"/> Torr	
	Operation Pressure ( )	<input type="checkbox"/> Pa • <input type="checkbox"/> Torr	
Differential Pressure	( )	<input type="checkbox"/> kPa • <input type="checkbox"/> kgf/cm <sup>2</sup>	
Permitted Helium Leaking Volume	( )	<input type="checkbox"/> Pa·m <sup>3</sup> /sec • <input type="checkbox"/> Torr·l/sec	
Water Cooling System	<input type="checkbox"/> Need • <input type="checkbox"/> Not Need		
Starting Torque	( )	<input type="checkbox"/> N·m • <input type="checkbox"/> kgf·cm	
Material (if special material required)	( )		
Surface coating(If special coating required)	( )		

•Please complete as much of the form as possible.

Diagrammatic illustration of measurement and loading

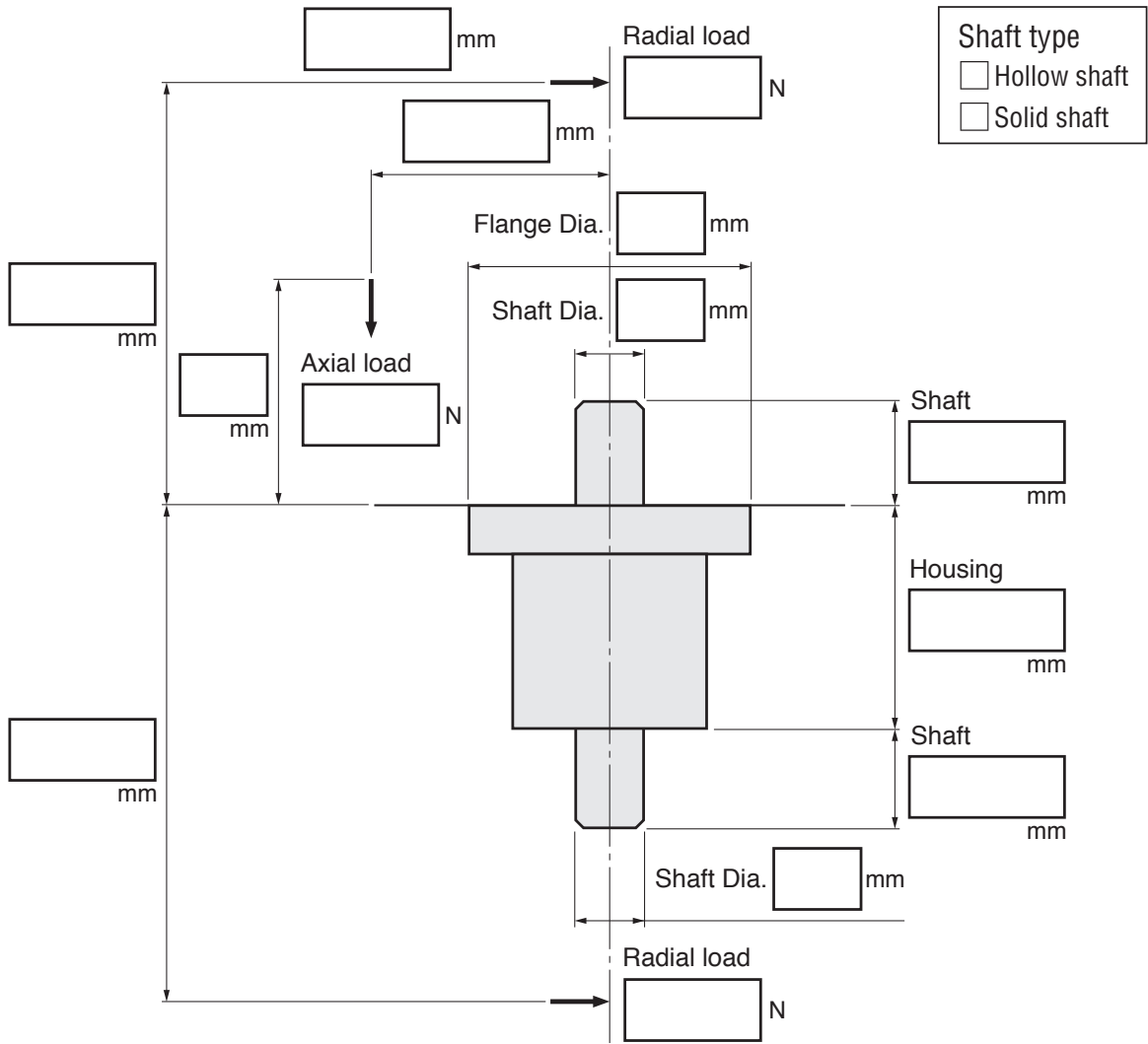

Memo

A large grid area for taking notes, consisting of a grid of small squares.

**Please contact below for any questions regarding our MFS.  
If technical or design information is required please fill out the design information sheet.**



**-For Semiconductor, FPD and PV industry-**

*〈Japan & Korea〉*

**Eagle Industry Co., Ltd.**

SI Corporate Planning Department.

1-12-15, Shiba-Daimon, Minato-ku, Tokyo, 105-8587, Japan

TEL: +81-3-3438-2394

FAX: +81-3-3438-2294

URL: <http://www.ekk.co.jp/>

*〈USA & outside of Japan for Semiconductor〉*

**EKK Eagle Semicon Components, Inc.**

1731 Technology Drive Suite 760 San Jose, CA 95110 USA

TEL: +1-408-573-9004

FAX: +1-408-573-9015

**-For other industries-**

**EagleBurgmann Japan Co., Ltd.**

Global Sales Control Department.

K BLDG, 514, Nakagawashin, Gosen, Niigata, 959-1693, Japan

TEL: +81-250-47-1172

FAX: +81-250-47-1173



Argentina · Australia · Austria · Belarus · Belgium · Bulgaria · Brazil · Canada · Chile · China · Colombia · Cyprus · Czech Republic · Denmark · Ecuador · Egypt · Estonia  
Finland · France · Germany · Great Britain · Greece · Hungary · India · Indonesia · Iraq · Israel · Italy · Japan · Jordan · Kazakhstan · Korea · Kuwait · Latvia · Libya  
Lithuania · Malaysia · Mauritius · Mexico · Morocco · Myanmar · Netherlands · New Zealand · Nigeria · Norway · Oman · Pakistan · Paraguay · Peru · Philippines · Poland  
Qatar · Romania · Russia · Saudi Arabia · Singapore · Slovenia · Slovakian Republic · South Africa · Spain · Sweden · Switzerland · Syria · Taiwan · Thailand · Trinidad and  
Tobago · Tunisia · Turkey · Turkmenistan · Ukraine · United Arab Emirates · Uruguay · USA · Uzbekistan · Venezuela · Vietnam · [www.eagleburgmann.com/world](http://www.eagleburgmann.com/world)



EagleBurgmann is one of the internationally leading companies for industrial sealing technology. Our products are used everywhere where safety and reliability are important: in the oil and gas industry, refining technology, the petrochemical, chemical and pharmaceutical industries, food processing, power, water, mining, pulp & paper, aerospace, semiconductor and many other spheres. Every day, more than 6,000 employees contribute their ideas, solutions and commitment towards ensuring that customers all over the world can rely on our seals. Our modular TotalSealCare service underlines our strong customer orientation and offers tailor-made services for every application.

### **EagleBurgmann Japan Co., Ltd.**

#### **Head Office**

1-12-15, Shiba-Daimon, Minato-ku, Tokyo, 105-8587, Japan  
Phone: +81-3-3432-0188 Fax: +81-3-3432-5448

<http://www.eagleburgmann.jp/>

# **EagleBurgmann®**